



**Ultraframe**<sup>®</sup>  
Transforming light and space



V4 | APRIL 2021



**INTERNAL  
INSULATED PELMET**  
SYSTEM OVERVIEW  
AND DESIGN GUIDE



## THE CONSERVATORY THAT THINKS IT'S AN EXTENSION

The insulated internal pelmet uses the well proven Ultraframe Classic Glazed Roof at its heart and then adds an engineered framing system internally which is plastered to give a perimeter ceiling all the way round.

This creates something that is neither conservatory nor extension. It combines all the benefits of the former in terms of light and then fuses this with the solidity and feel of an extension. This effect can be played up or down depending on whether glazed walls or masonry walls are specified. **All of this can be achieved at a price point not dissimilar to that of a standard conservatory.**



### WEATHER TESTED

**Watertight in winds up to 130mph**

- **Triple layer storm shield** at radius end.
- Unique **double skin** top caps and **adjustable speedlocks** designed to optimise glazing bar compression.
- Sturdiest, most **durable** gaskets and glazing stops.

### EASIEST

**The simple and most intuitive to fit**

- Click-fit speedlocks and top-caps.
- Loaded with features for a **fast fit, first time**, every time.
- **No cutting or drilling** on site.
- Comprehensive installation guides and videos.

### VERSATILE

**The most configurable roofing system available**

- Low pitch eaves beam and variable ridges for **pitches from 2.5 to 40.9°**.
- **Advanced software** to instantly validate structural requirements of any large shape and complex designs.
- Integrated structural solutions for **large spans** of bi-folding doors.

### TRUSTED

**The original and most loved glazed roof**

- Over **1.5 million roofs** installed.
- The first roofing system to be **approved by BBA**.
- **Made in Britain** for over 35 years.

### SAFEST

**The only roof engineered to postcode**

- NASA satellite data used to calculate the maximum wind AND snow load requirements.
- Specialist software will engineer every critical element of the roof for optimum deflection, compression and tension.
- **Super strong** eaves beam, ridge, valley and jack rafter.

### CUSTOMISABLE

**Unbeatable range of design options**

- Add shape and elegance externally with a choice of **4 unique Cornices**.
- Create thermally efficient, cosy and stylish rooms with **insulated pelmets and columns**.
- **Bespoke colours** in painted aluminium or foiled.
- **Finishings and crestings** to suit all tastes and budgets.

## CONTENTS

<b>Introduction and System Overview</b>	page 2 - 3
<b>Standard Details</b>	pages 4 - 7
<b>Typical Cross Sections</b>	pages 8 - 13
<b>Every day shapes</b>	page 14
<b>Case Study</b>	page 15
<b>Notes</b>	page 16



Externally, this design features Cornice.

## PRODUCT DEFINITION

**An engineered steelwork ladder system that forms a framework relying only on the roof for support onto which plasterboard is screw fixed.**

## CONSUMER BENEFITS

- Enjoy the light from a conservatory with the feel of an extension - providing greater overall value and the best of all worlds.
- Creates a whole new dynamic to the space - a 'real room/living room' feel.
- You can maintain light and space by using windows all round OR have brick piers to give a greater sense of solidity.
- A holistic 10 year guarantee is issued to your chosen retailer.
- Better thermal efficiency when compared to a standard conservatory.
- This real room/living room feel means more styling and furnishing options and the perimeter ceiling is perfect for down lighters.

## TRADE BENEFITS

- As are all Ultraframe's products, the insulated internal pelmet was extensively tested in the R&D facilities at Head Office.
- This is a systemised approach, yet maintains flexibility for the retailer.
- Steel work ladder framework and roof are integrated as the additional weight is accounted for in Ultraframe's U-Design software which up-specs roof according to postcode and loadings.
- Allows completion of the complete glazed roof externally and internally before steelwork ladder system is installed.
- Steelwork ladder framework system is supplied on the same lead time as the roof.

## KEY PERFORMANCE CRITERIA

- Can be used from 15 - 40 degrees.
- Steelwork ladder system extends from 300mm to 1200mm.
- Datum point is internal side frame to external face of 12.5mm plasterboard.
- The system is not designed to carry additional suspended weight - e.g. - flatscreen tv's.
- Can be used with standard eaves or Super Duty version with box gutters & bolsters and accommodates differential pitches across hips.
- If your chosen design features a box gutter, we strongly suggest you use a 30mm frame add-on around the head of all frames, which allows the plasterboard to run underneath the box gutter for a neater finish.

## PRODUCT OVERVIEW

### TRANSOM BAR

- 1 Your sealed unit of choice.
- 2 CHA400GR/4 Painted stop bead.
- 3 12.5mm plasterboard (not supplied) screwed to steel framework.
- 4 CHA001 Transom Bracket.
- 5 CHA600GR/5 Cloaking panel closure trim (with sealing foam).
- 6 Steelwork ladder takes support at eaves and from glazing bars.
- 7 Plasterers 90° angle bead (not supplied)
- 8 CHA405 Perimeter channel.
- 9 25mm Heatguard polycarbonate 'cloaking panel' supplied.
- 10 PFTB 'V' groove fascia is standard fitment.
- 11 CHA002 Cloaking panel support clip.
- 12 Optional cornice externally may have been specified on your project.
- 13 Standard eaves beam illustrated - Super Duty version may be specified on your project.
- 14 18mm moisture resistant timber packer is necessary when using Cornice on cill.



### GEORGIAN BOLSTER BAR

- 1 Bolster Corner Infill



## PRODUCT OVERVIEW

### BOX GUTTER - with frame add on

Framework terminates on host wall.



### BOX GUTTER - without frame add on (retro fit situation)

Framework terminates on fascia



## PRODUCT OVERVIEW

### GABLE FRAME SITUATION



If this is a new installation of an insulated internal pelmet then the design of the gable frame should cover the 'open end' of the ladder framework. On retro fits where a redesign of the gable feature is not feasible, the application of a privacy film to the glass may suffice.

### GALLOWS BRACKET PRE - PREPARATION

On an installation of roof and insulated internal pelmet you **MUST** have this situation when you arrive on site. Structurally, it is not permissible to insert this packer / spacer when the roof is already glazed.

**Packer / Spacer slips over**



**Finished installation - 165mm**



**Box Gutter - 265mm**

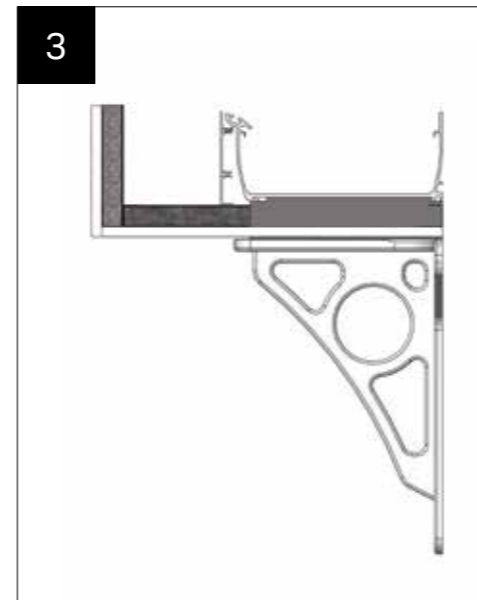

## LIGHTING LAYOUTS

Into the 12.5mm plasterboard, can be inset down lighters. The ladder steelwork framework provides the perfect vehicle to transport wiring back to the dwelling's wiring circuits.



## OPTIONAL CORNICE EXTERNALLY

Cornice can be used to give additional visual interest. It can be used with standard eaves beam or with the Super Duty eaves beam. Corner covers for 135 and 90 degree corners are now featured as standard (135° for curved cornice only).

1 Tier Cornice



2 Tier Cornice



3 Tier Cornice



Curved Cornice



## TYPICAL CROSS SECTIONS

### STANDARD EAVES

Ladder framework terminates on Fascia

Here we have the ladder steelwork terminating on the PFTB plank fascia (using standard eaves beam).

This detail is used when there are window frames around the complete perimeter and where there are no box gutters included in the design.

This design is also used if the ladder is retro fitted to an existing Ultraframe roof.

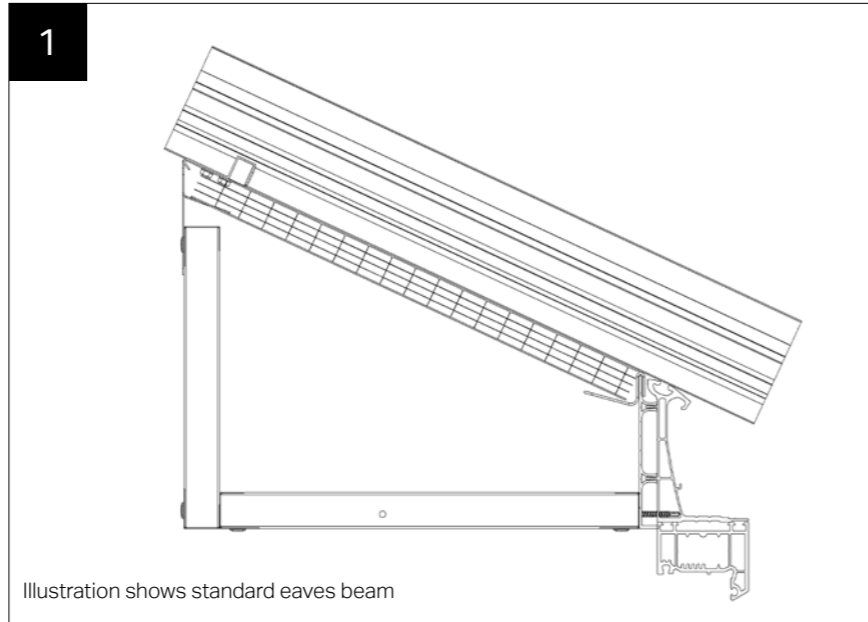

### STANDARD EAVES

Ladder framework terminates below Fascia

This detail is used when there is a box gutter included in the design. The steelwork ladder terminates underneath the PFTB plank fascia.

Please note the following;  
- window frames all round, a frame add-on of at least 30mm must be used.

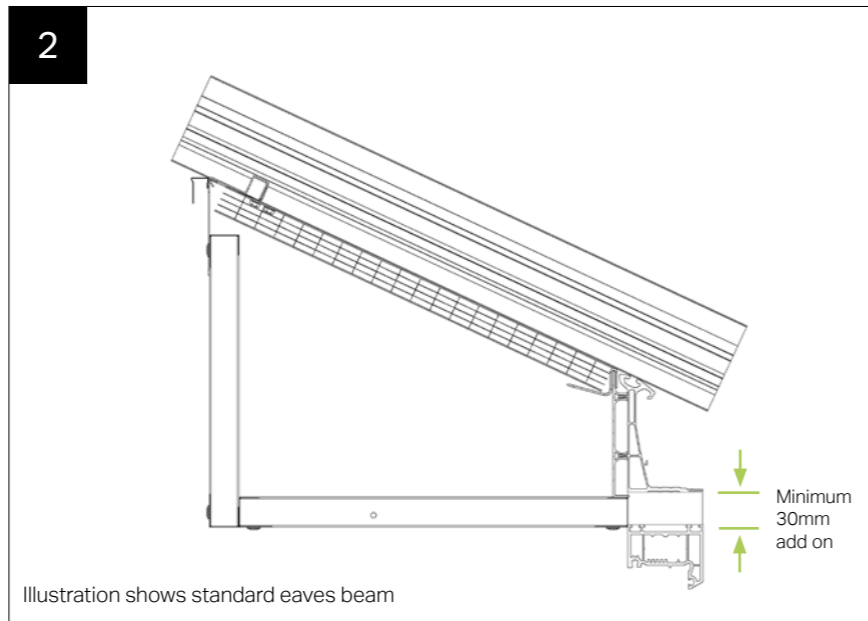

### SUPER DUTY EAVES

Ladder framework terminates below fascia

Here we see the roof sat onto window frames featuring the Super Duty eaves beam which is used over large door openings

The ladder steelwork terminates under the PFTB plank fascia.

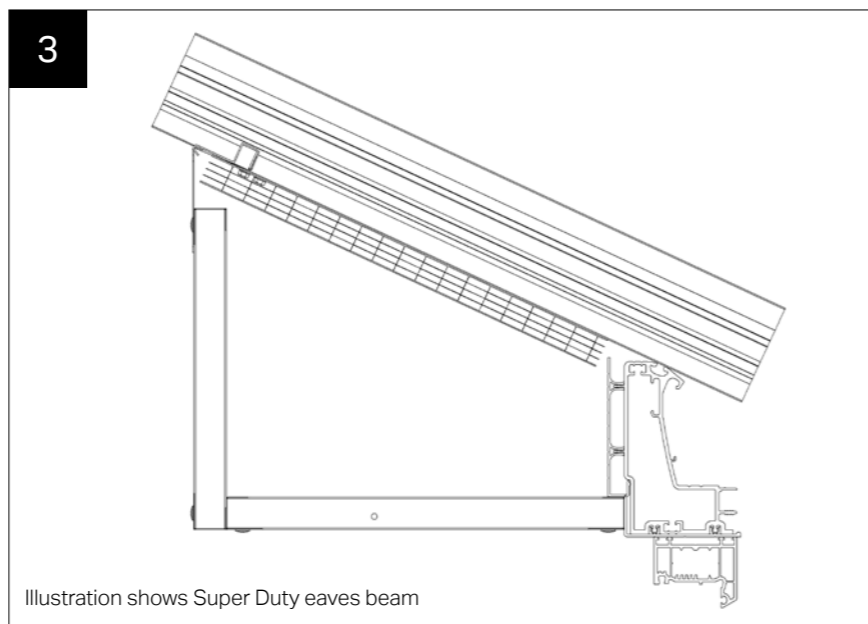

## TYPICAL CROSS SECTIONS

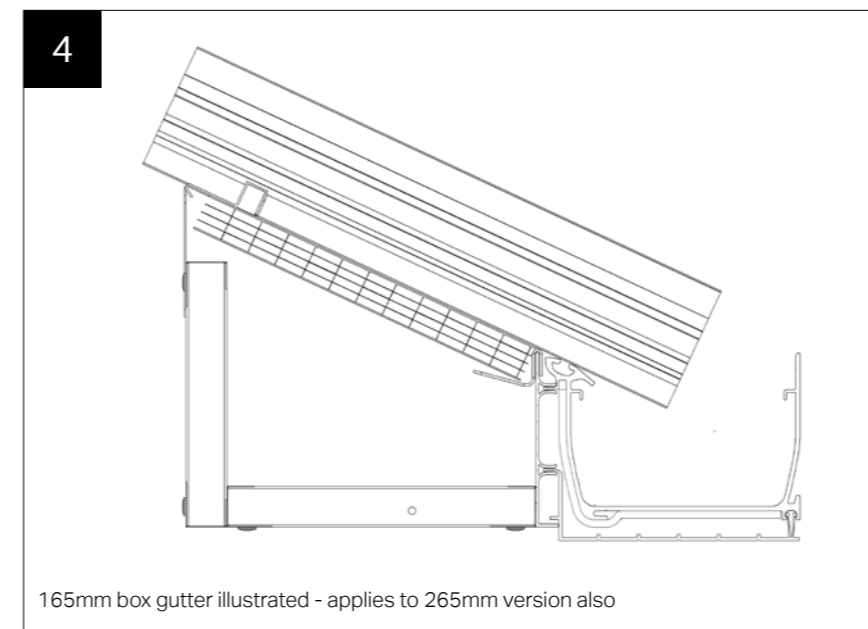

### BOX GUTTER

Terminates on fascia

This detail is created when the ladder steelwork framework is retrospectively fitted to an already built conservatory.

Horizontal ladder framework terminates onto the box gutter cladding.

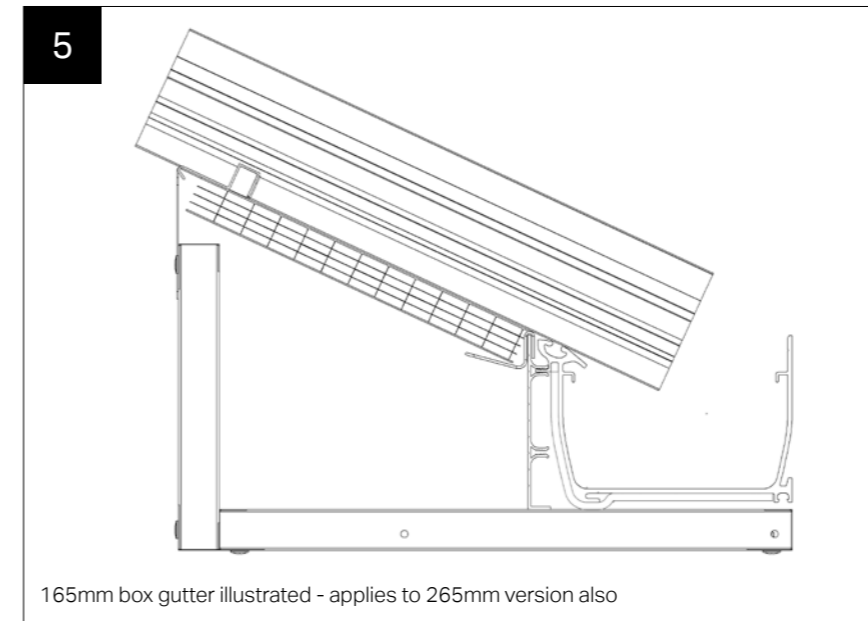

### BOX GUTTER

Terminates below fascia

When starting a new installation that features a box gutter, this is the way the ladder framework is finished at the box gutter.

To ensure this detail is executed accurately, it is necessary to undertake the following;  
- window frames all round, a frame add-on of at least 30mm must be used.

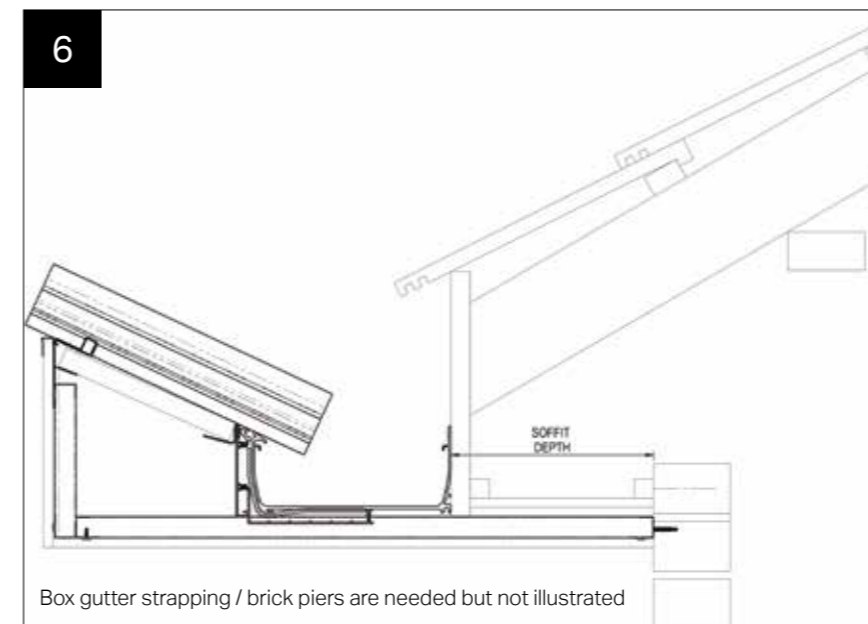

### BOX GUTTER

Terminates onto bungalow fascia

To achieve this detail a 30mm add on is required and this allows the horizontal ladder to sail through to the host wall.

Please supply soffit depth when ordering

## TYPICAL CROSS SECTIONS

### BOX GUTTER

#### Raised back

When the conservatory design features a raised back box gutter, this is the detail.

Please note the rule about 30mm add-on/cill applies.

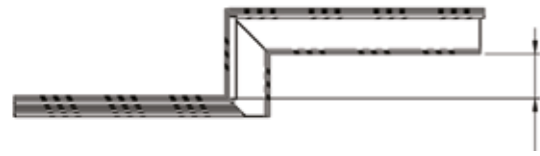

Plan View: Raised back box gutter

### BOX GUTTER

#### Masonry parapet wall

In this situation, a brick pier internally is necessary to support the box gutter. Straps are necessary to resist wind uplift.

2x required on each pier



CHA165 or CHA265  
Box gutter support packer  
165 or 265

### STANDARD EAVES

#### On cill

A minimum 30mm cill is needed to create this detail.

Horizontal ladder terminates below fascia. Internal block work MUST allow horizontal framework to fly through without interference.

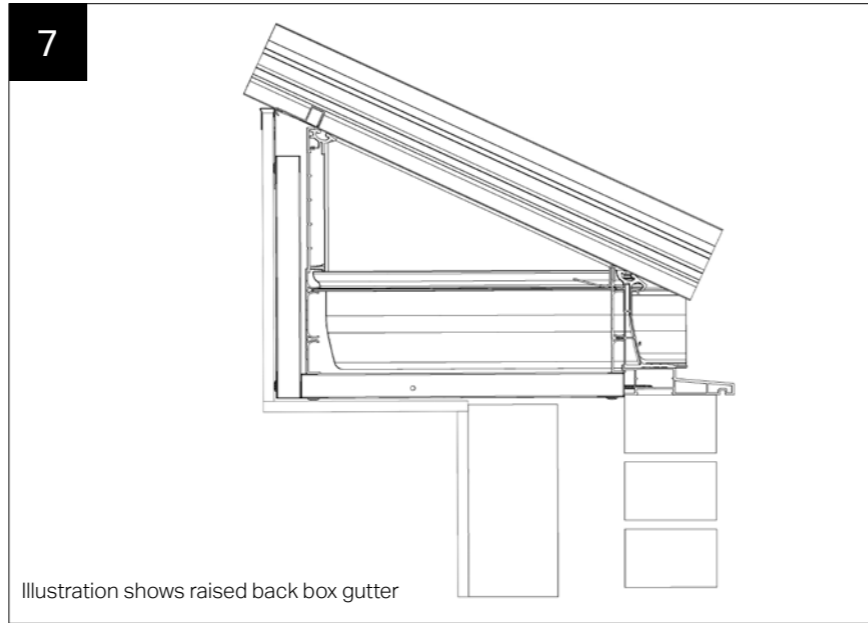

Illustration shows raised back box gutter

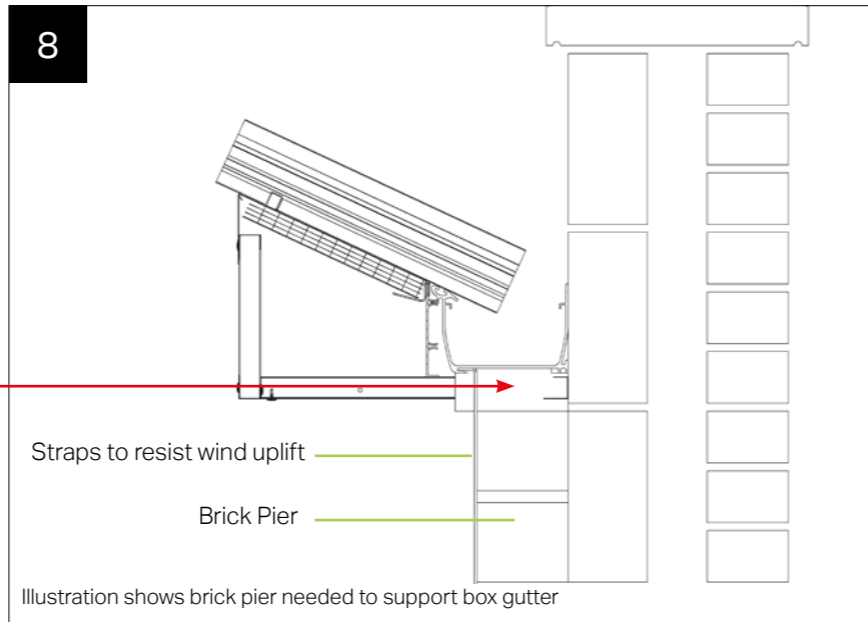

Illustration shows brick pier needed to support box gutter

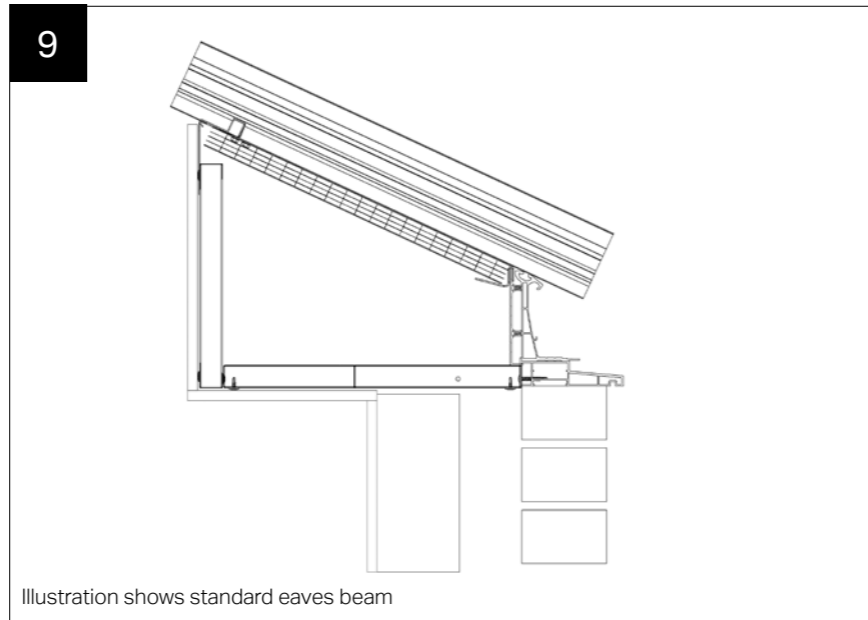

Illustration shows standard eaves beam

## TYPICAL CROSS SECTIONS

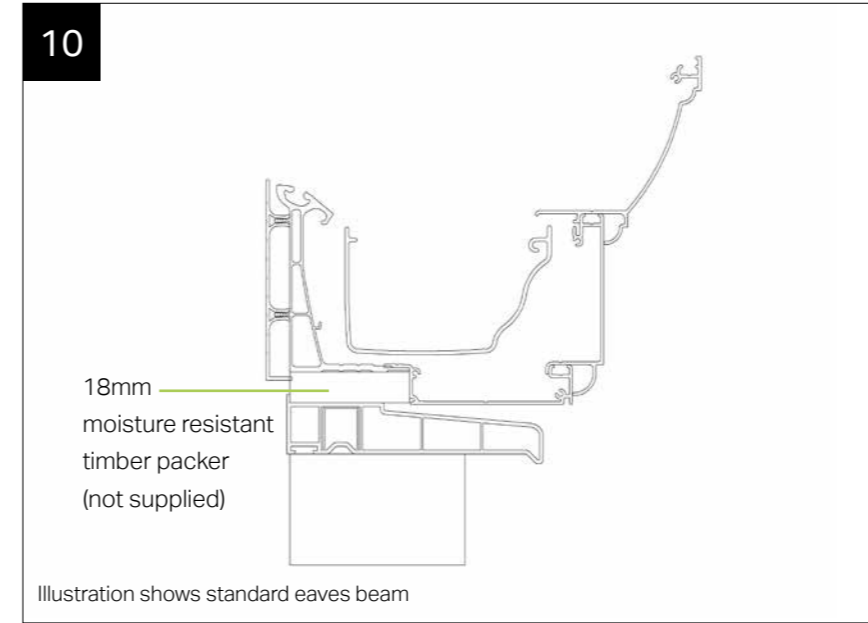

Illustration shows standard eaves beam

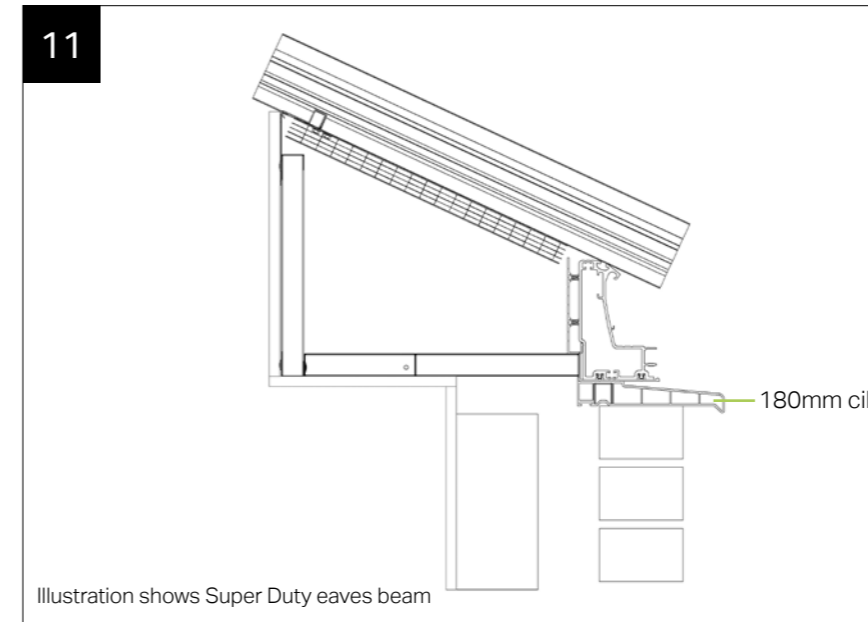

Illustration shows Super Duty eaves beam

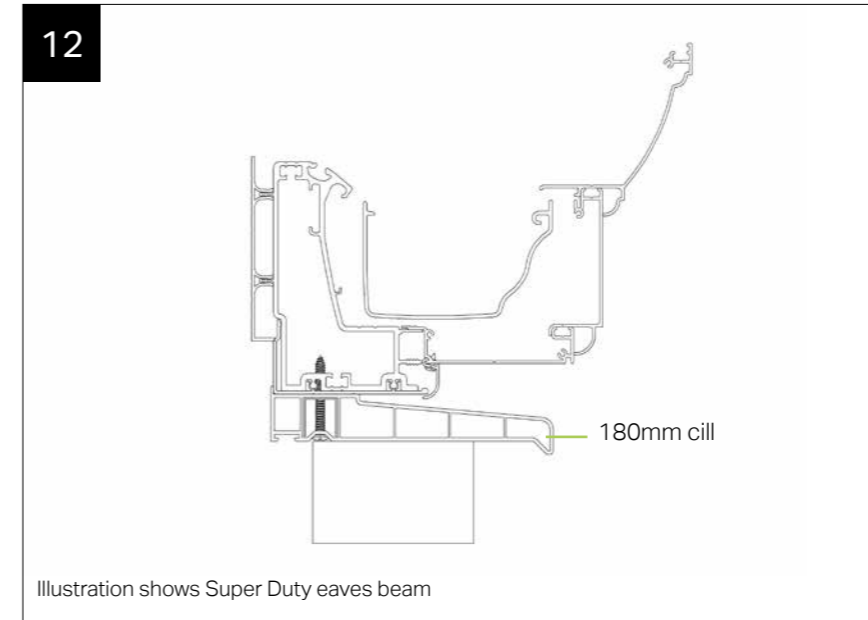

Illustration shows Super Duty eaves beam

### STANDARD EAVES BEAM

#### On cill with Cornice

When Cornice is used with a cill an 18mm moisture resistant timber packer is inserted.

### SUPER DUTY EAVES BEAM

#### On cill

When building the roof onto masonry, recommended good practice detail is to use a cill.

As the Super Duty eaves beam sits 'inboard' a further 25mm, we suggest using a 180mm cill.

As drawn, the ladder steelwork terminates below the PFTB plank fascia.

### SUPER DUTY EAVES BEAM

#### On a 180mm cill with Cornice

In this situation, we recommend a slightly deeper cill than on standard eaves beam.

TYPICAL CROSS SECTIONS

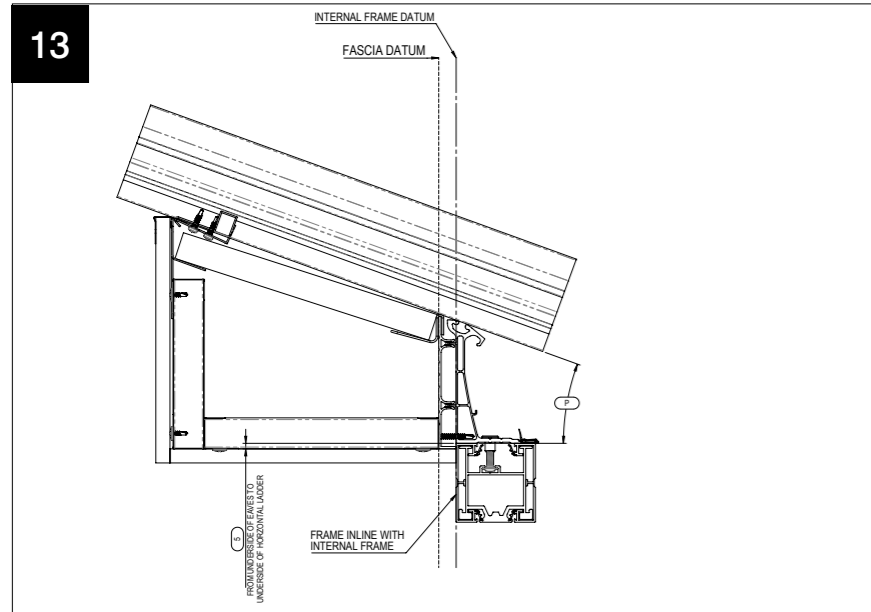

Bi fold support on fascia

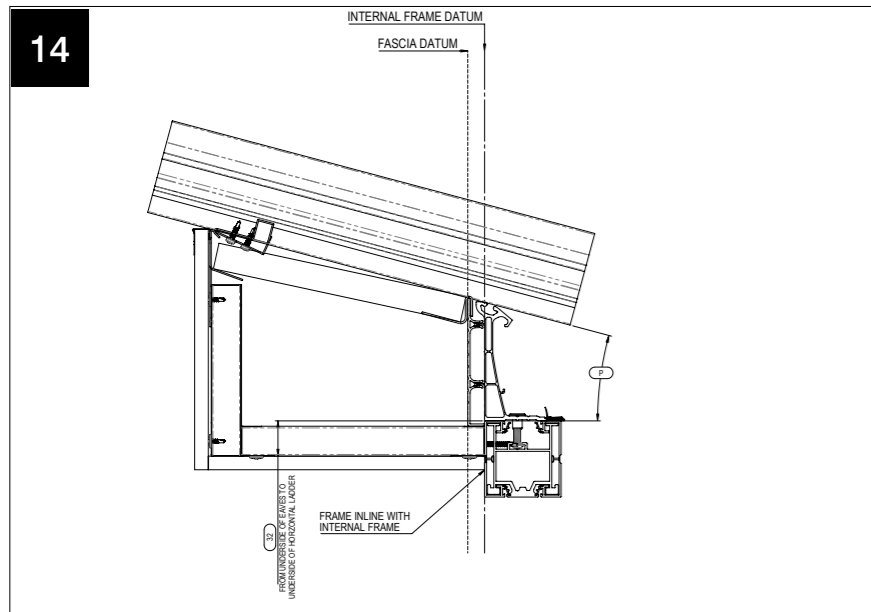

Bi fold support below fascia

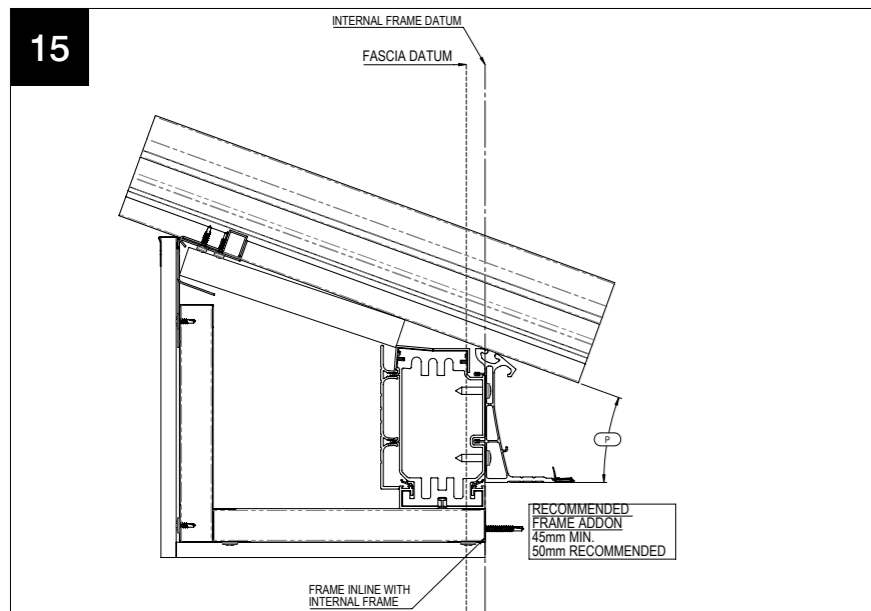

Eaves super bolster  
Above 20° below fascia only

TYPICAL CROSS SECTIONS

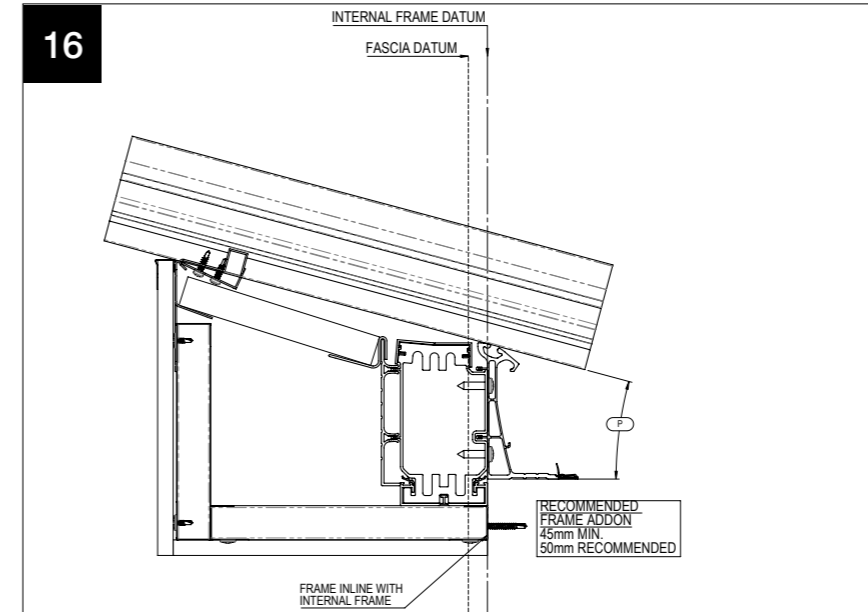

Eaves super bolster  
Below 20° below fascia only

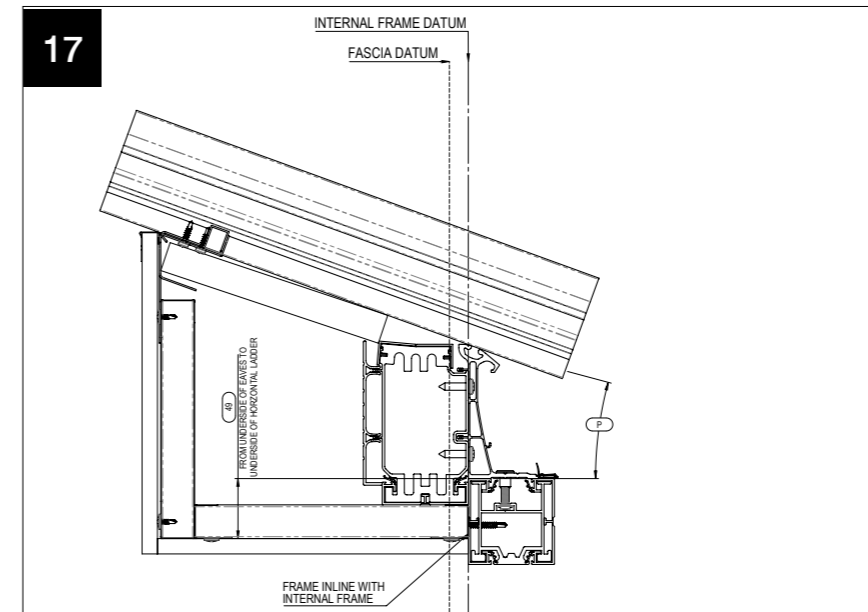

Above 20° combination support  
below fascia only

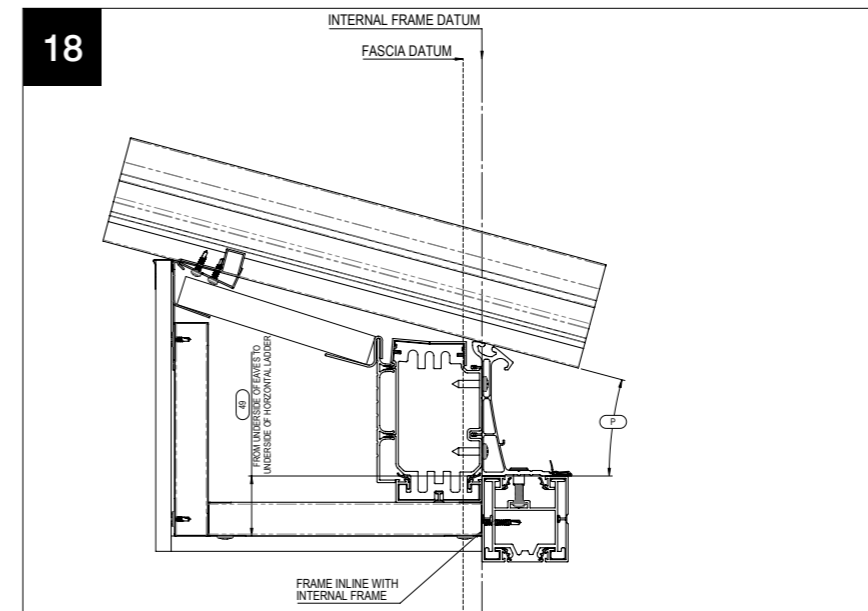

Below 20° combination support  
below fascia only

## EVERYDAY SHAPES

N.B. Shapes not identified below that feature a valley may incur an additional manufacturing charge.

### VICTORIAN OPTIONS

EQUAL BAY



DOUBLE ENDED



STRETCHED FRONT



VICTORIAN / GEORGIAN



### LEAN-TO OPTIONS

STANDARD



HIPPED



HIPPED HYBRID



WRAP-A-ROUNDS



### GEORGIAN OPTIONS

STANDARD



DOUBLE ENDED

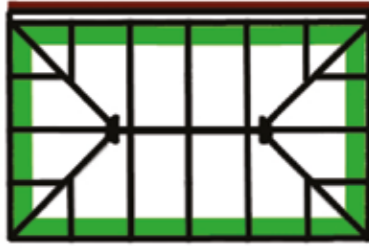

HYBRID



 Denotes the area covered by the insulated pelmet (orangery sections). Please note that the Orangery section widths will vary dependant on roof pitch.

### GABLE OPTIONS

STANDARD



DOUBLE ENDED



 Cloaking requirements for gables.

This needs to be considered as part of the design and is the responsibility of the retailer to supply and install the materials required to clad off the 'open' end.

## CASE STUDY

When selling an internal insulated pelmet, it is important to understand that where the design features different pitches - as illustrated - the projection of the ladder framework is varied between elevations. (The height of the pelmet is constant across elevations). Images lifted from U-Design software.

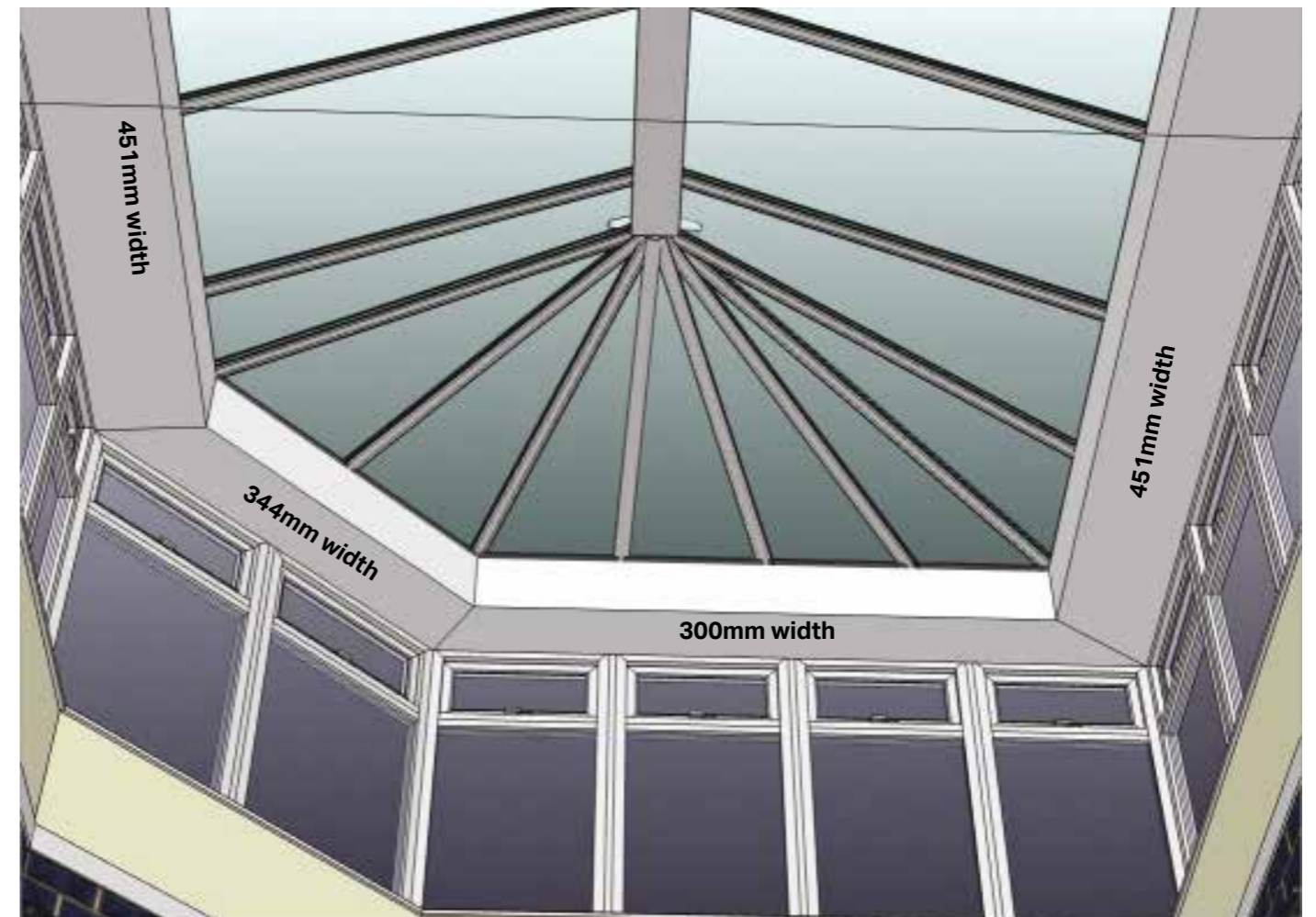
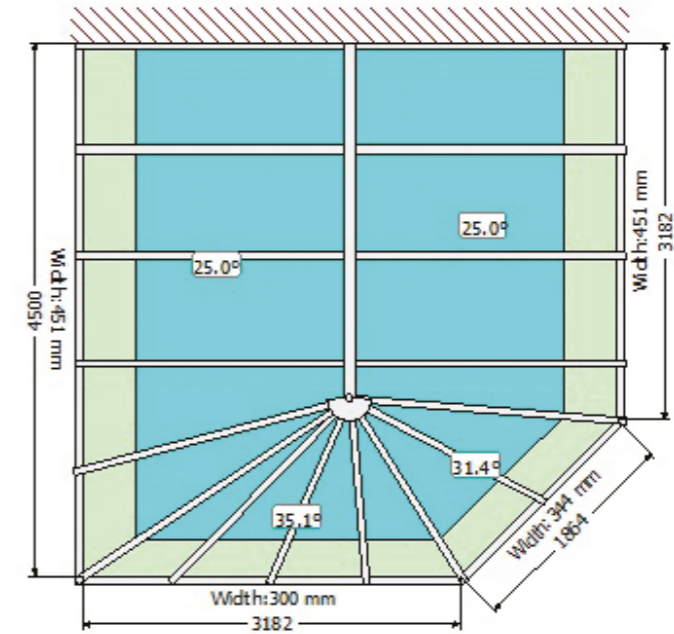



[www.ultraframetrade.co.uk](http://www.ultraframetrade.co.uk)

**Job No.: 2390 4/21 V4 CHA021**

It is Ultraframe's policy to continually seek to improve its products, processes and services, and we reserve the right to change specifications without prior notice. Ultraframe is a trading name of Ultraframe (UK) Limited.



**Ultra**frame<sup>®</sup>  
Transforming light and space