

ROOF FITTERS: Ensure this guide is passed to your plasterer to ensure a quality install.



SEE p19 FOR GUIDANCE

V9 | April 2021

INTERNAL INSULATED PELMET

Suitable for Quantal Aluminium Roof - See p2

INSTALLATION GUIDE

Dear Customer,

Thank you for choosing the internal insulated pelmet perimeter pelmet system. This guide should ensure installing the class leading product couldn't be more straightforward.

Before you commence installation of the internal insulated pelmet, please take a few minutes to familiarise yourself with the fitting sequence. Ensure that if a box gutter gallows bracket is fitted it has the space/packer installed (see page 9).

Internal insulated pelmet is suitable to be attached to either the Ultraframe Classic System, the Quantal Aluminium Roof or the Ultrasky Orangery Roof.

Any feedback - positive or negative - is welcomed so we can make our product even better. Please contact the Technical Support Team on 01200 452918 or email techsupport@ultraframe.co.uk

PLEASE USE THE LOCATION PLAN/SETTING OUT DETAILS PROVIDED - SEE EXAMPLE ACROSS

CONTENTS

Chambered Eaves	2
Preambles and tools	3
Product overview	4-7
Component identification chart	8
Gallows bracket pre-preparation	9
Location plan and installation sequence overview	10
Eaves ventilation pre-preparation	11
Internal Insulated Pelmet installation steps - standard	12-19
Plasterboarding and plastering	19
Bolster Bar installation steps	20-27
Gable installation	28-29
Valley installation	30-33
Box Gutter installation	34-35
Typical cross sections	36-41

ULTRAFRAME EAVES

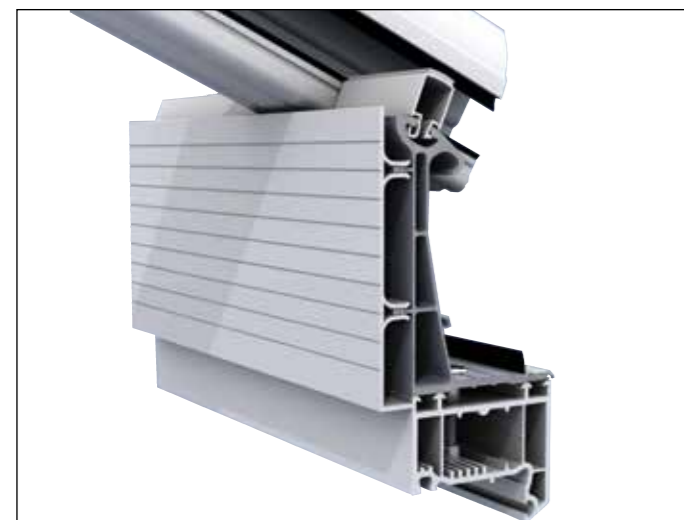

QUANTAL EAVES

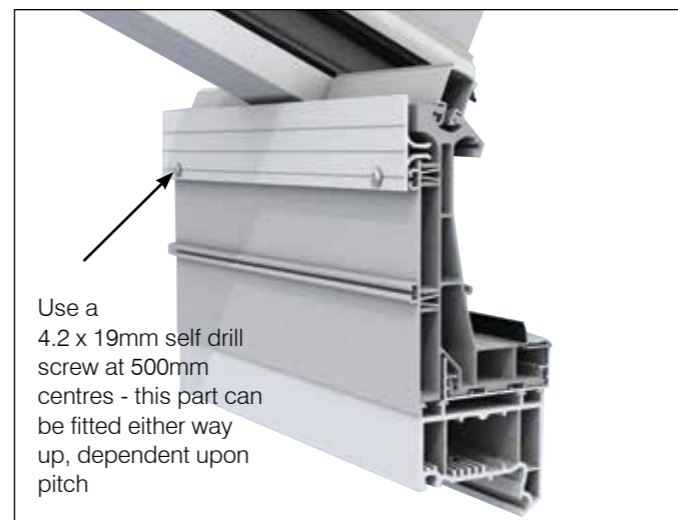

This guide shows fitment of internal insulated pelmet to Ultraframe eaves (left) - if using the Quantal roof your fascia should look like this (right) prior to commencing internal insulated pelmet fitment.

TOOLS REQUIRED



Long nose pliers



Tin Snips



No. 2 Phillips drive Bit



Drill/Screwdriver



Hack Saw



10mm Drill Bit

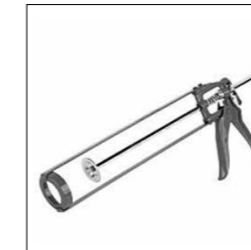

Sealant Gun



Angle finder



Tape Measure



Spirit Level (magnetic)

Materials you need to supply

- 12.5 mm foil backed plasterboard
- Thin wall Gyproc angle beads
- Joint tape
- 18 mm moisture resistant timber packer (only needed for Cornice on a cill)
- Adjustable support prop to temporarily support horizontal ladders.

See p19 for further guidance on plasterboarding



Adjustable Support Prop

General points

Care should be taken when handling components that are seen by the homeowner, as surfaces may be scratched if not handled with care. Choose a suitable area for unpacking the components and always check them before fitting. Any claims for missing or damaged parts are only accepted in line with our standard terms and conditions of sale.

Health & Safety

Site safety is paramount. The Construction (Design & Management) Regulations 2015 apply to the whole construction process, on all construction projects from concept through to completion. Compliance is required to ensure construction projects are carried out in a way that secures health and safety. The installation company shall be responsible for the safety of all of the fitting team, the customer and members of the public.

The Surveyor should have carried out a risk assessment to reduce risk on site and this should have been discussed with you prior to starting.

Please use safe working platforms and ladders that comply with BS EN 131. Always use equipment in line with manufacturers recommendations. Personal Protective Equipment – such as goggles, mask and ear defenders – should be used.

Careful consideration should be given to the safe disposal of all packaging – Ultraframe packaging is predominantly made from recycled materials and can be readily recycled.

Product Internal Insulated Pelmet

Supplied with a location plan and, of course, this installation guide. The location plan is used to match individual components to their respective position. Our numbering convention always starts at the top left.

The Superstructure

Ensure that all frames and masonry walls are vertically plumb, which will then allow perfect alignment.

Downlighters must be LED IC fire rated, see page 19.

Technical Support

Tel: 01200 452918

Email: techsupport@ultraframe.co.uk

Set out & Bracket Dimensions		
Job No: WUG0001 (910386)	Batch/DB: J0	Stock Code:
Customer: CONTEST (Concoid Testing)	Manufacture: 29/09/2011	Glazing Code: 25C
Ref:	Despatch: 30/09/2011	Ext. Finish: WHITE/
Notes:	Hub: CLUTHEROE	Int. Finish: /WHITE

Fix Horizontal Ladders On Internal Fascia

Standard Brackets Bar Position(s)	CHA 001 mm	CHA 003 mm	CHA 000 mm	CHA 011 mm	Bolster Slits Bar Position(s)	CHA 009 mm	CHA 010 mm	CHA 012 mm	CHA 013L mm	CHA 013R mm

Typical Location Plan provided with internal insulated pelmet

PRODUCT OVERVIEW

Transom Bar

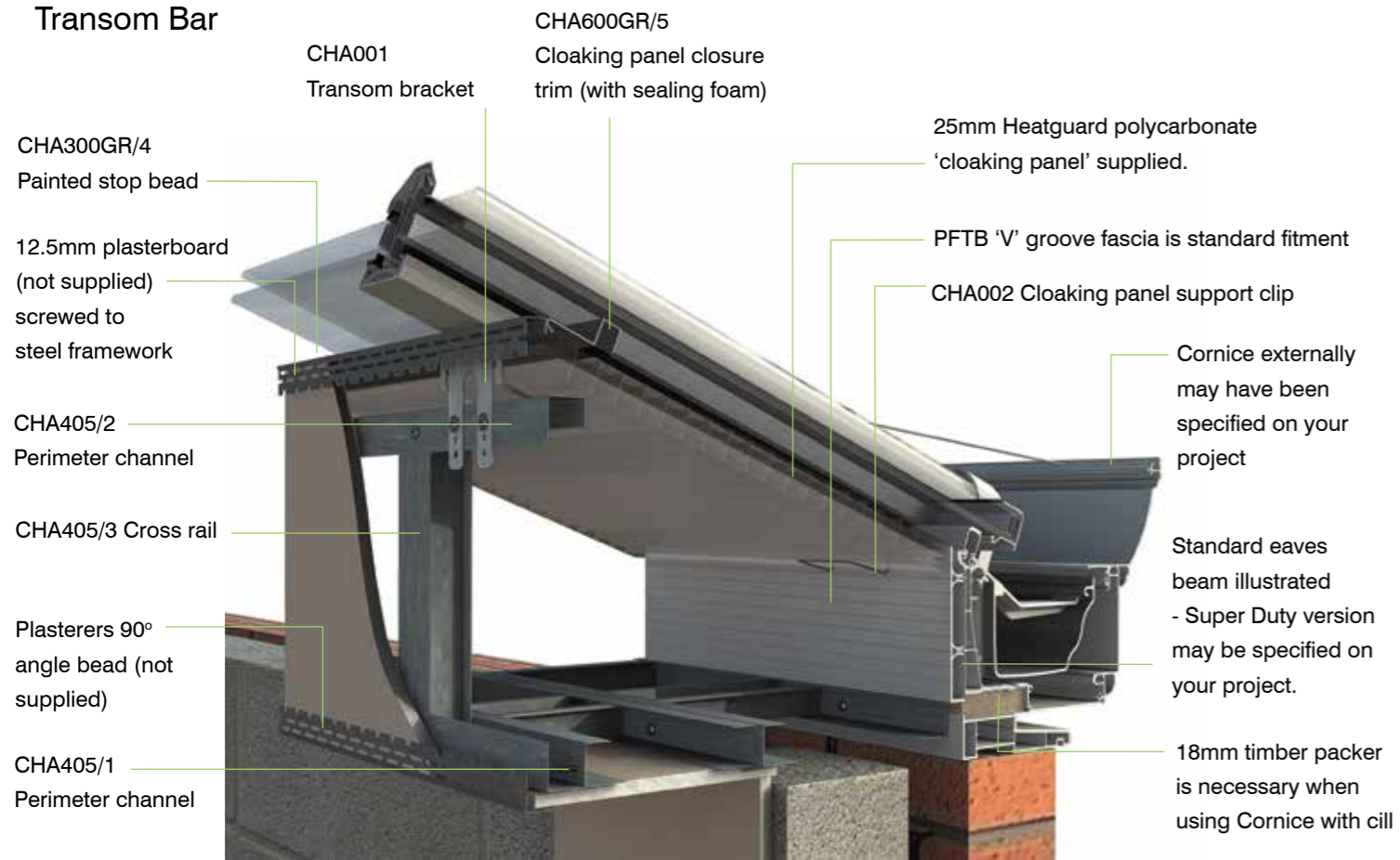

Georgian Bolster Bar



Bolster Corner Infill

PRODUCT OVERVIEW

Box Gutter - with frame add on



Framework terminates on host wall.

Box Gutter - without frame add on (retro fit situation)



Framework terminates on fascia.

PRODUCT OVERVIEW

Box Gutter - with raised back



PRODUCT OVERVIEW

Valley Section

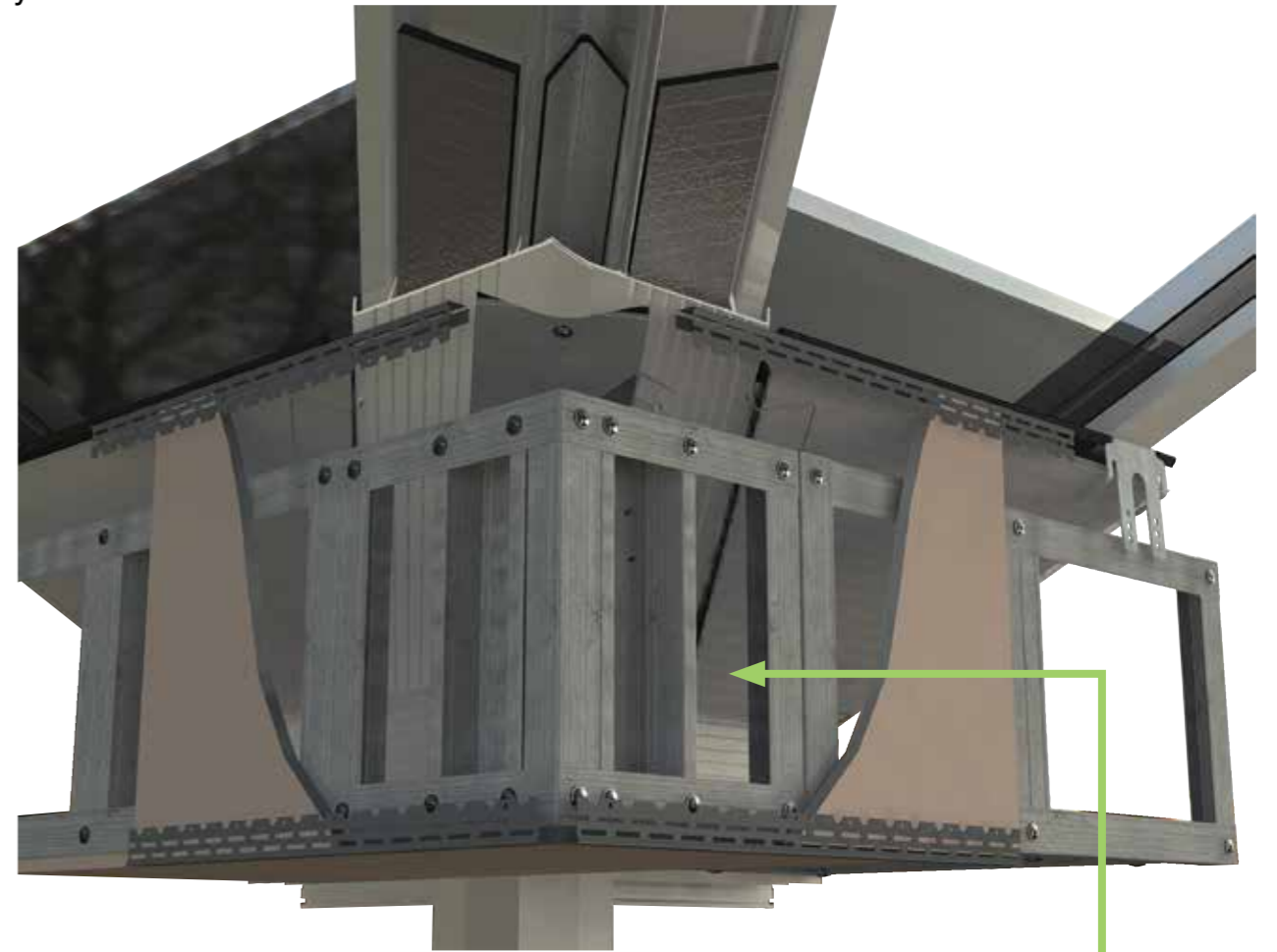











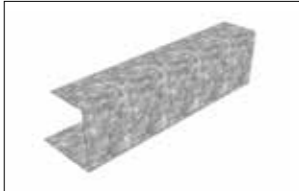
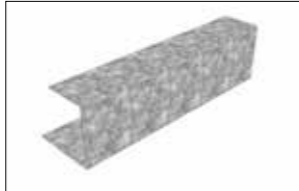
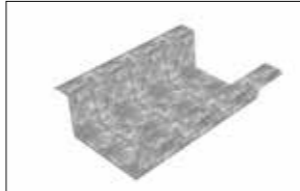





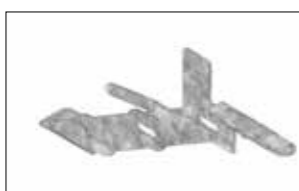
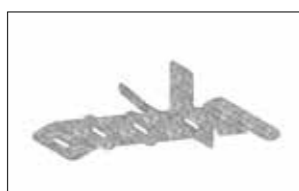



Gable Frame Situation

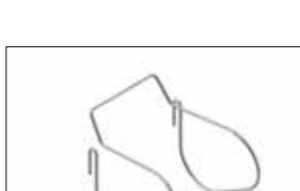

VALLEY - Reverse angle

If this is a new installation of internal insulated pelmet then the design of the gable frame should cover the 'open end' of the ladder framework. On retro fits where a redesign of the gable feature is not feasible, the application of a privacy film to the glass may suffice.

COMPONENT PARTS LIST

 CHA405/1 Perimeter Channel - PIERCED	 CHA405/2 Perimeter Channel	 CHA405/3 Crossrail Channel	 Bolster Corner Infill
 CHA001 Transom Bracket	 CHA090 Georgian Hip Bracket	 CHA003 Hip Bracket Adjustable	 CHA011 Splay Bar Bracket Assemble
 CHA013L Closure Trim Support Bracket LH (Bolster)	 CHA013R Closure Trim Support Bracket RH (Bolster)	 CHA009 Bolster Transom Bracket	 CHA010 Bolster Hip Bracket Assembly
 CHA012 Bolster Splay Bar Bracket	 CHAA006 BAG OF 25 - M4 x 13 Self Drill Philips Wafer Head	 CHA007 BAG OF 25 - 4.2 x 19 Self Drill Philips Head Screw	 CHA008 BAG OF 25 - 4.8 x 32 Self Drill Philips Pan Head
 CHA002 Poly Panel Spring Clip	 CHA004 Poly Support Wire Form Bolster Spacer	 CHA015 Super Duty Eaves Poly Support Clip	 CHA200/7 Vent Foam
 CHA600GR/5 & CHA300/6 Top Cavity Closing Trim & Sealing Foam	 CHA300/GR/4 1.25mm Plaster Stop Edge Bead - Painted	 CHA165 or CHA265 Gallows Packer 165 or 265	 CHA005 Single Tie Bar Cover

Should you find damaged or missing components, please always reference replacements with both a parts code (see above) and/or its position on the location plan. This will help with the speedy resolution of any issues.

GALLOWS BRACKET PRE - PREPARATION

Packer / Spacer slips over



On an installation of roof and internal insulated pelmet you **MUST** have this situation when you arrive on site. Structurally, it is not permissible to insert this packer / spacer when the roof is already glazed.

Finished installation you need to find



Box Gutter - 165mm

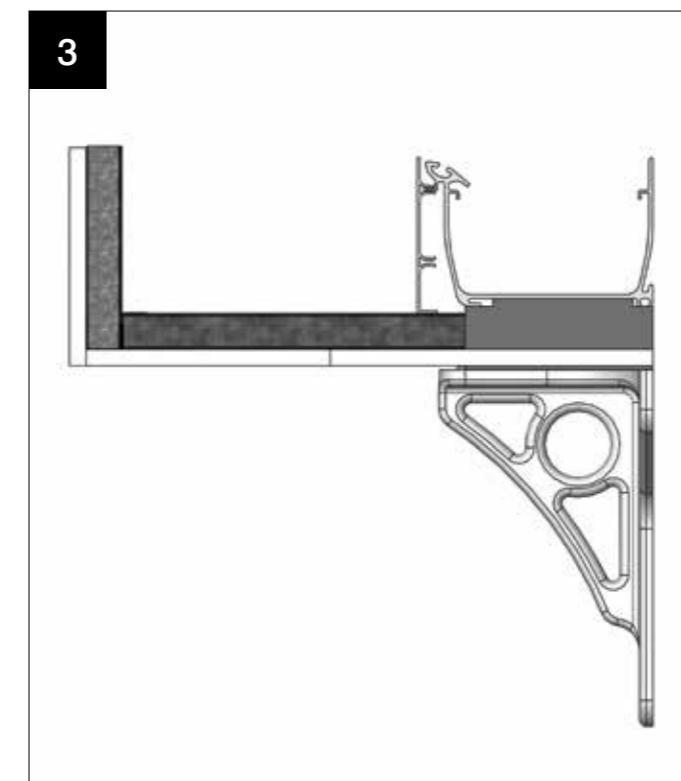

Box Gutter - 265mm

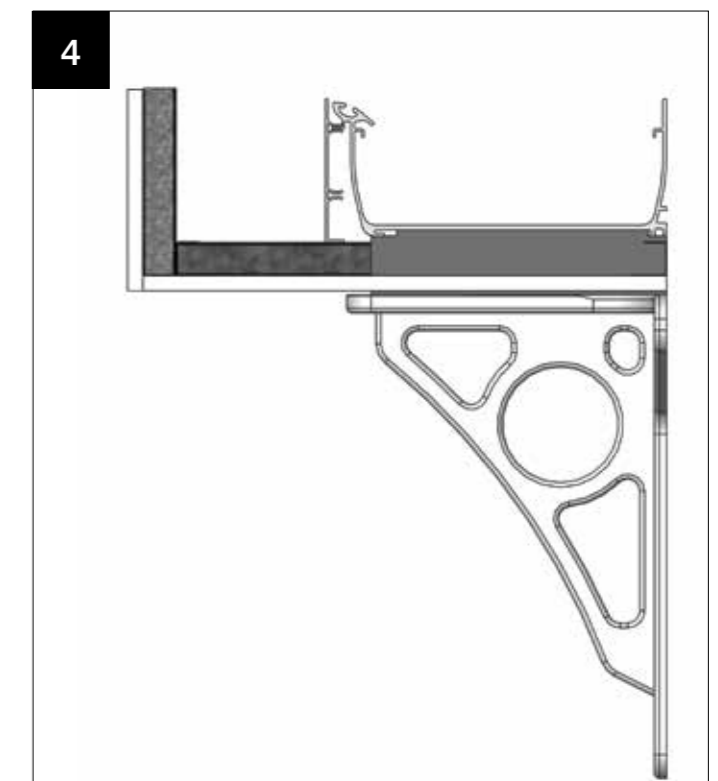

LOCATION PLAN

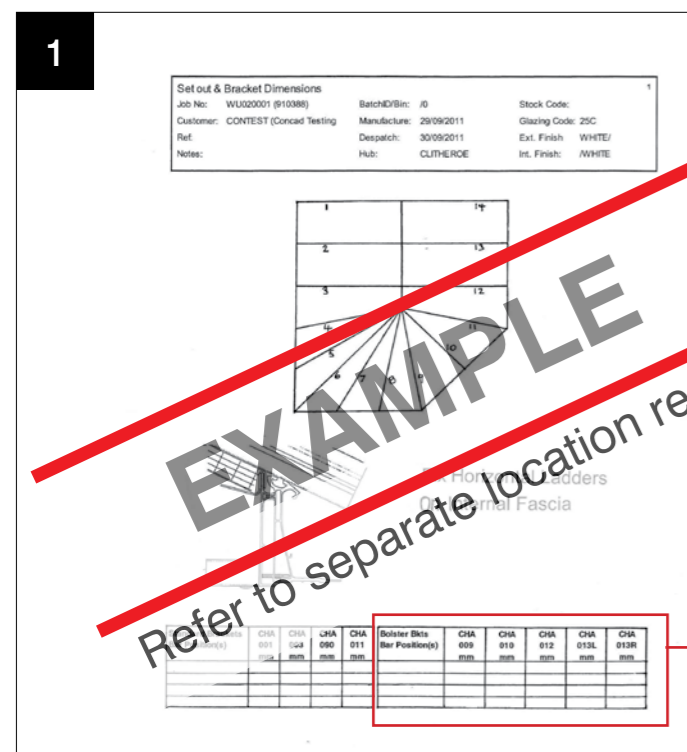

The internal insulated pelmet component location plan is packed in the component box.

The location plan indicates bracket measurement / position and component positions.

Bolster bar set outs - see page 20

INSTALLATION SEQUENCE

Additional notes if Bolsters fitted*

- A** FIT VENTILATION FOAM
- B** FIT BRACKETS **N.B** NOT GEORGIAN IF BOLSTERED*
- C** FIT POLYCARBONATE CLOAKING SCREEN CLIPS TO FASCIA
- D** FIT CLOSURE TRIMS BETWEEN BRACKETS
- E** FIT POLYCARBONATE CLOAKING SCREEN **N.B** FIT POLYCARBONATE CLOAKING SCREEN SUPPORT CLIP TO SCREEN IF BOLSTERED*
- F** FIT HORIZONTAL LADDER & TEMP SUPPORT **N.B** FIT CORNER LADDER INFILLS IF BOLSTERED*
- G** FIT VERTICAL LADDERS
- H** FIT PLASTERSTOP EDGE BEAD

INSTALLATION - VENTILATION



FITTERS TIPS - Some consider it good practice to silicone seal round ends of support trim

When the roof and internal insulated pelmet are ordered together, this ventilated glazing support trim arrives with breather foam already inserted into the cavity to prevent insect ingress.

If internal insulated pelmet is being installed into an existing older roof, it is important that the steps to the right and below are followed.

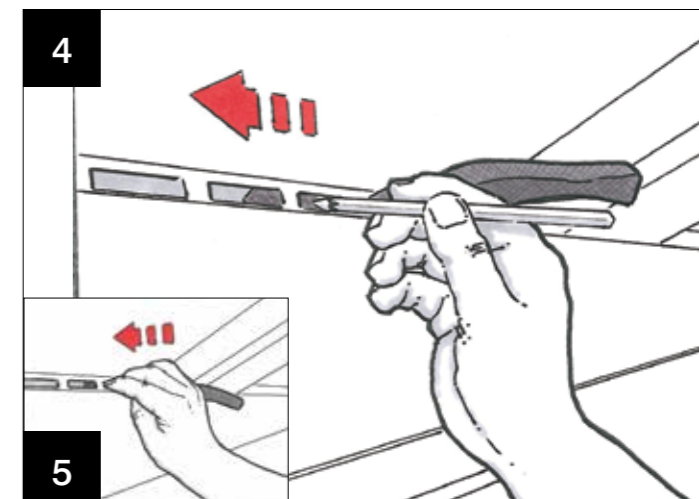

If the existing roof already has Eavesflow ventilators fitted, unclip and dispose of the ventilators and then introduce the foam strip using a pencil and thread along until all the slots have the foam behind.

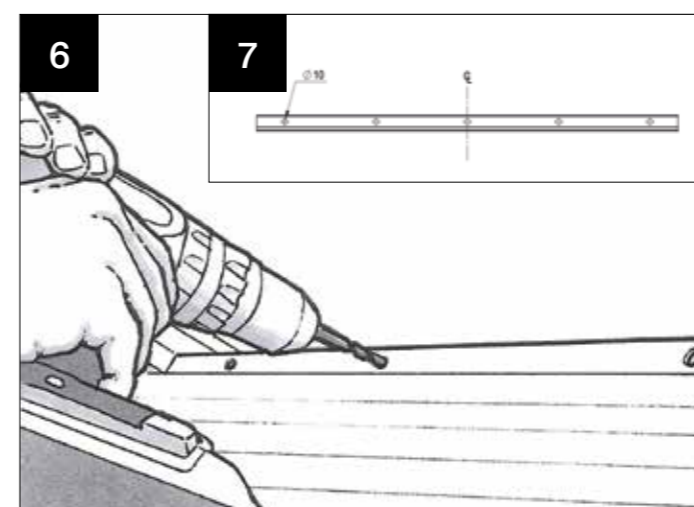

If the existing roof doesn't have Eavesflow fitted, then take a 10mm drill and drill through the glazing support trim from inside to outside to create 5 holes per 'bay' - ensure this is done over the length of 250mm, centred in the middle of the glazing panel.

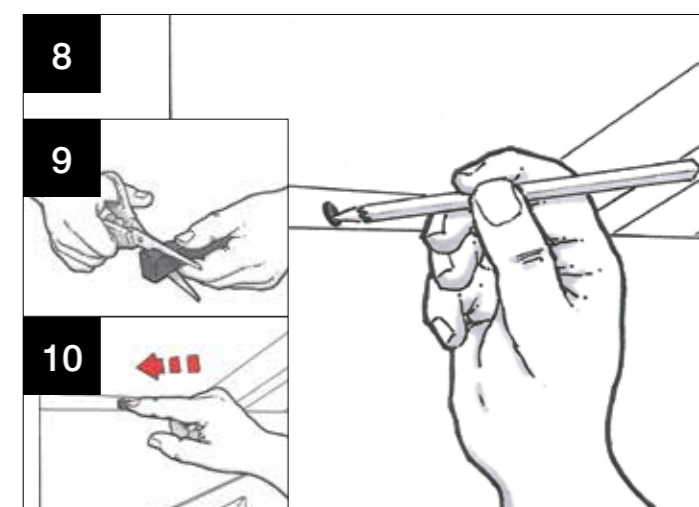

Now, cut the foam strip into 25mm pieces and insert into each hole, ensuring it sits comfortably and unobtrusively into each hole.

INSTALLATION - BRACKETS

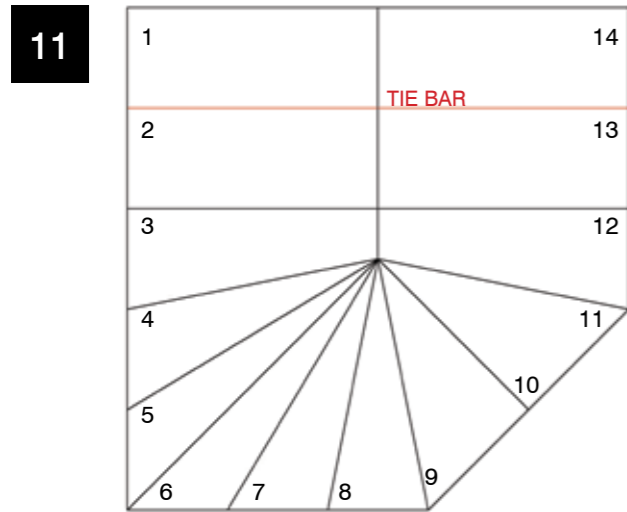

12

ROOF POSITION	STANDARD BAR BRACKETS POSITION (mm)			
	CHA001	CHA003	CHA090	CHA011
1, 2, 3, 12, 13, 14	200			
4, 5			389	
6			382L/389R	
7, 8			382	
10	384		384L/384R	
11			384R/384L	
	TRANSOM	ADJ HIP	GEORGIAN HIP	SPLAY

EXAMPLE
Refer to separate location report

IMPORTANT NOTE: Left (L) and right (R) dimensions are viewed internally.



Measurements are ALWAYS from the top edge of the PFTB fascia board.

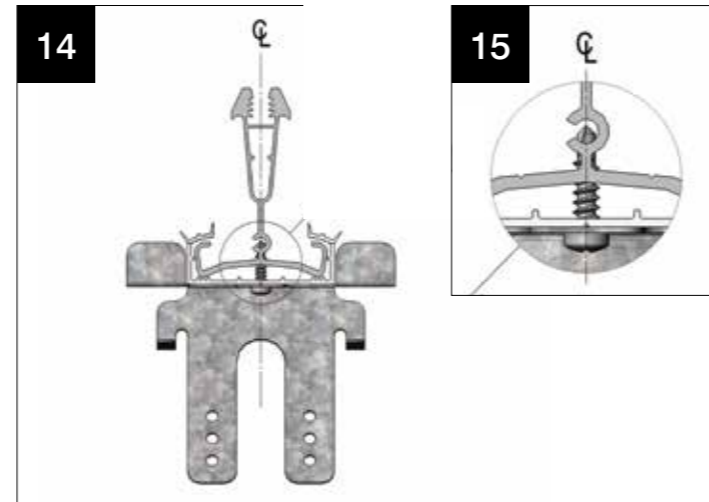

NOTE: Bracket fixing screws must be fit central of glazing bar, mark up the centre line of the bar on to the undercladding if it is not clear by sight.

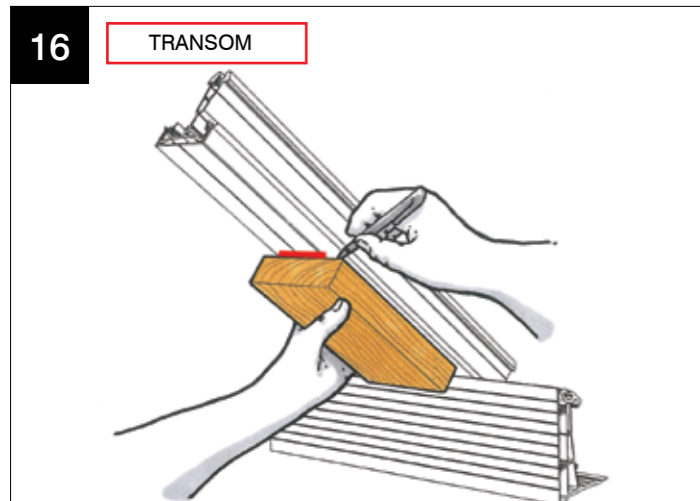

Using the location plan provided – see example above - find the dimension for setting out clip positions on the transom bars. Measure up the bar from top edge of fascia board, and mark it (see 13 above). If your roof features many transom bars, it may be simpler to cut a piece of timber to length and use as a template.

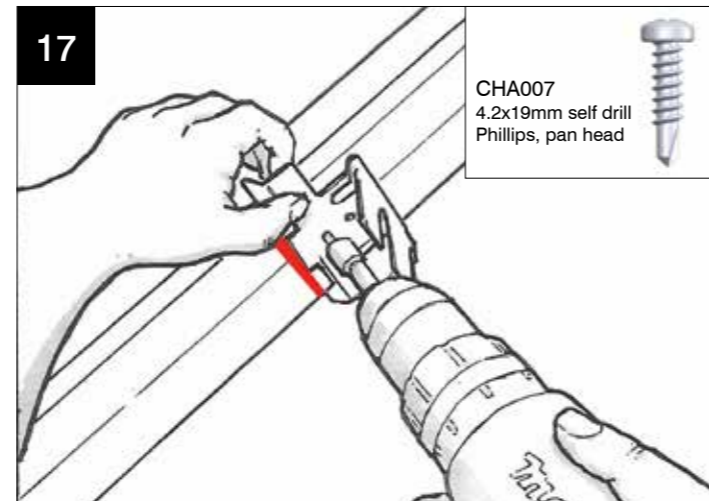

Take the transom bracket (CHA001) and attach using two 4.2 x 19mm self drill Phillips pan head screws supplied- the back edge of the bracket should butt up to the pencil line.

INSTALLATION - BRACKETS

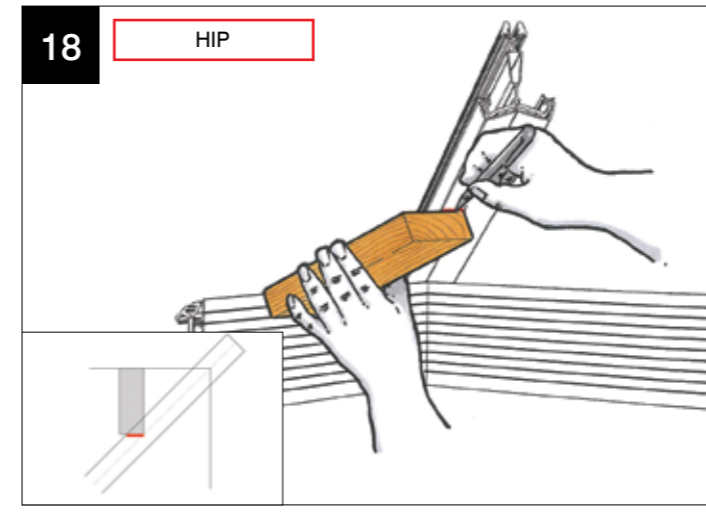

Similar to step 16, seek the set out dimension from the location plan (12) for the Georgian or Victorian bar. Mark with a pencil line. Please note the dimension will be different from the transom bar. This graphic shows the left hand dimension being marked. Timber template to be held square to fascia board.

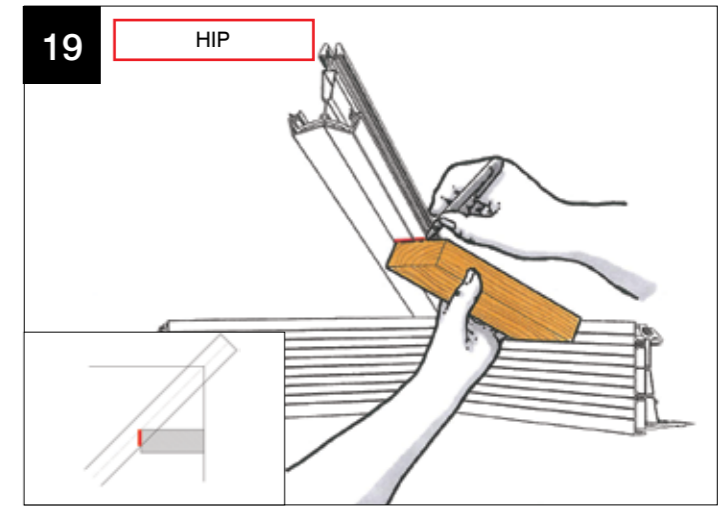

From the location plan, now mark the right hand fixing position.

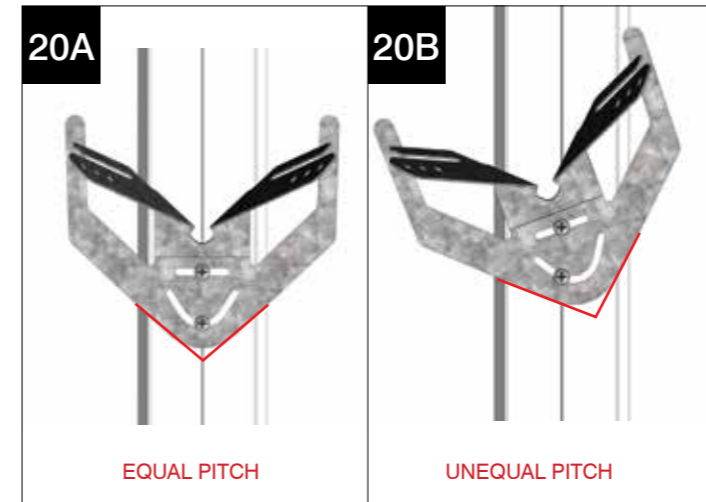

Now offer up the Georgian hip bracket (CHA090) – where the roof is equal pitch across the hip, the bracket should sit as (a). On unequal pitches, the bracket may be skewed as in (b)

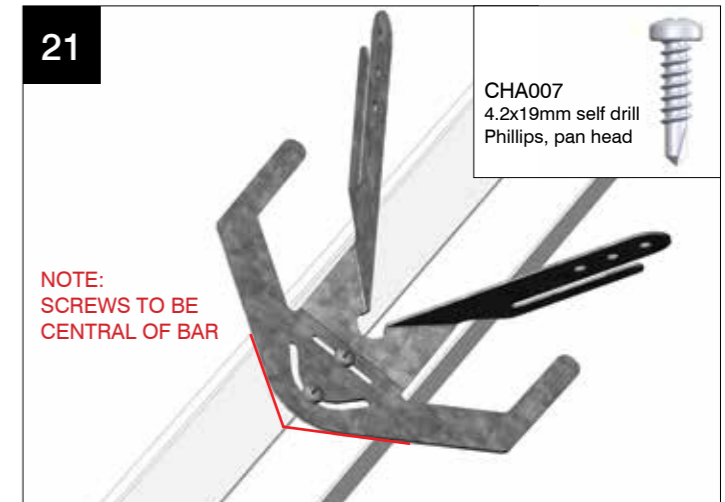

Now attach using one of the two 4.2 x 19mm self drill Phillips pan head screws supplied – one screw curved top slot - do not 'nip up' at this stage, but allow bracket to pivot.

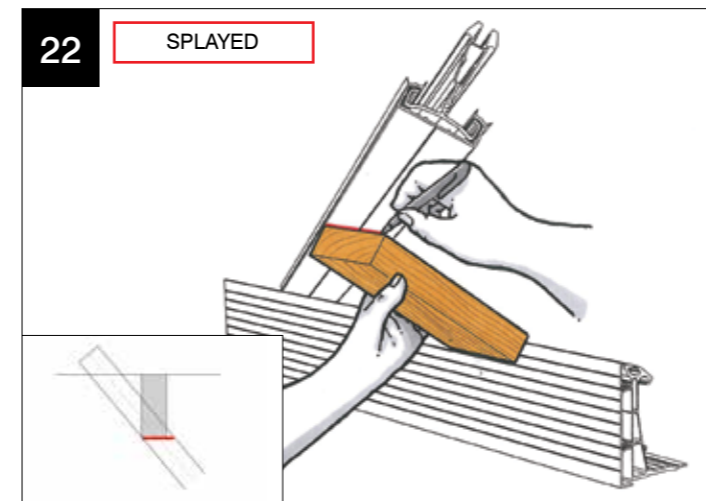

On a splayed bar – 7 and 8 on the sample location plan – measure and then strike a line across the face of the splayed bar's undercladding. Timber template to be held square to fascia board.

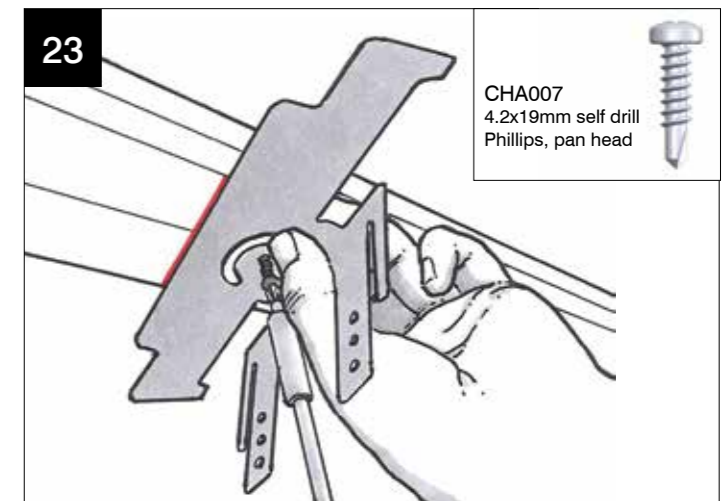

Now attach bracket CHA011 using one 4 x 19mm self drill Phillips pan head screw – ensure screw in curved slot is in centre line of bar.

INSTALLATION - BRACKETS / CLOAKING PANEL CLIPS

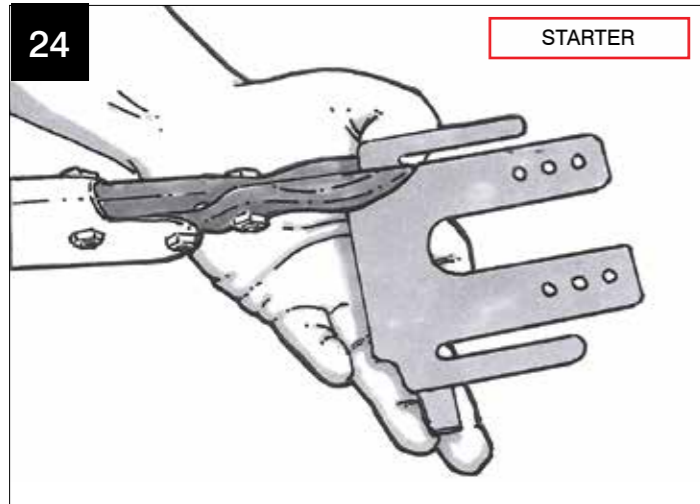

On the starter bar, take a CHA001 Transom bracket and snip off the long leg tab – if the wall is already plastered, further trimming may be required.

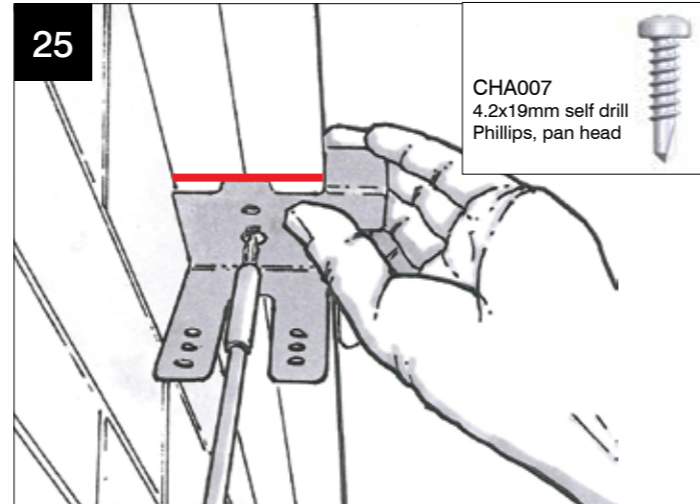

Measure, mark and fit the trimmed down starter bracket using two 4.2 x 19mm self drill Phillips pan head screw.

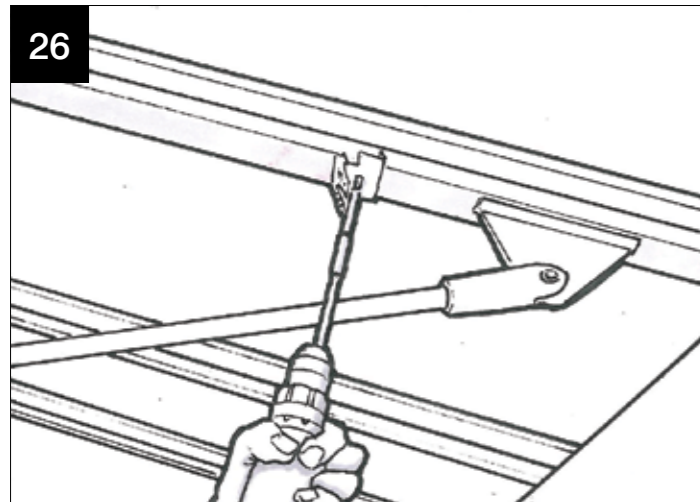

When there is a transom bracket on the same glazing bar as a tie bar, it is suggested that a long driver bit is used to facilitate easy fitment.

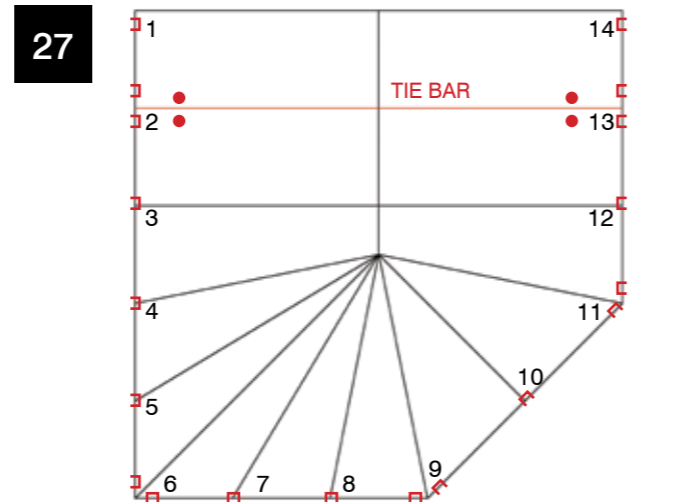

Symbol '□' shows if one support clip is needed central to the bar or one each adjacent to the bar - see 28 and 29 below. Additional CHA004 brackets '•' at tie bar position - see steps 41 & 42.

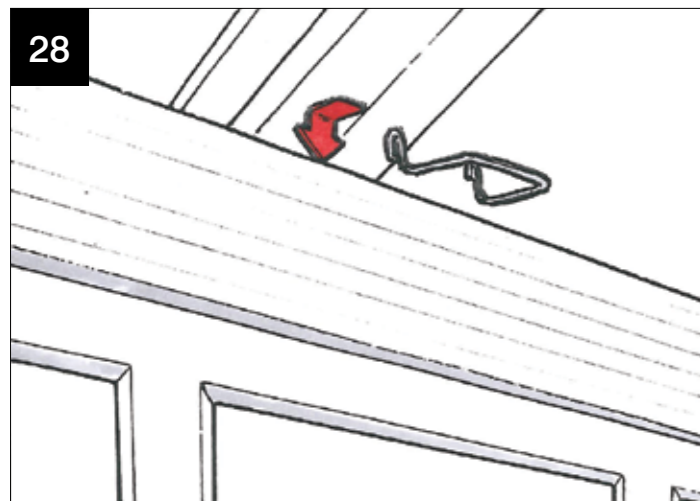

Over the planked fascia board at the eaves, at each transom (but not tie bar locations) and splayed bar position, hook over the cloaking panel support clips CHA002.

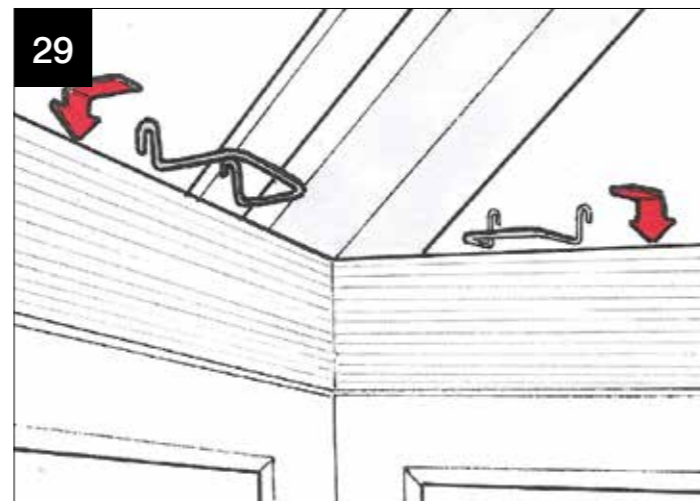

On starter bars, hip bars and transoms with tie bar brackets, a cloaking panel support clip is placed each side of the bar.

INSTALLATION - CLOAKING PANEL CLIPS

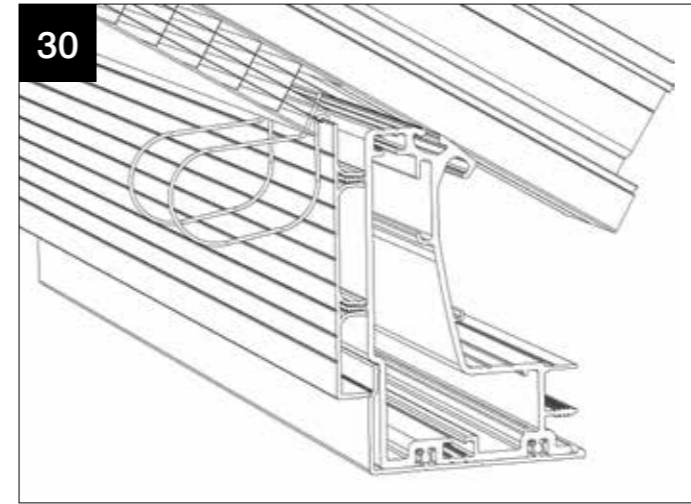

IMPORTANT NOTE: If Super Duty eaves beam is used, then these are the cloaking panel clips that are supplied.

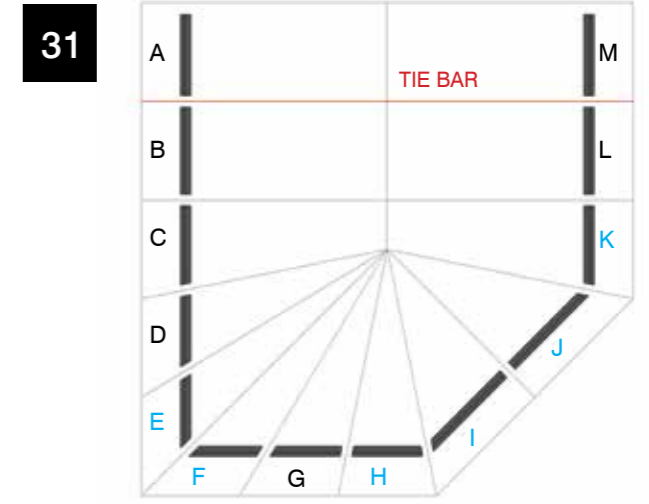

Select the cloaking panel (polycarbonate) support trim for the positions indicated in Black (A, B, C, D, G, L, M).

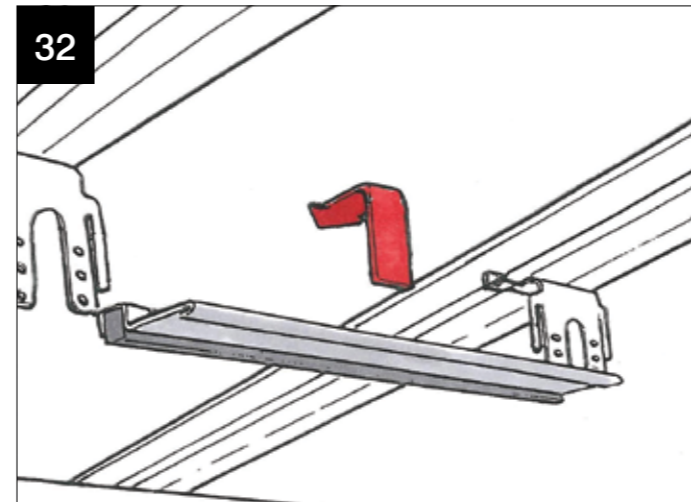

Offer into position the cloaking panel (polycarbonate) support trim – this is lifted up and over the two tabs – one per side of either the transom or Georgian brackets.

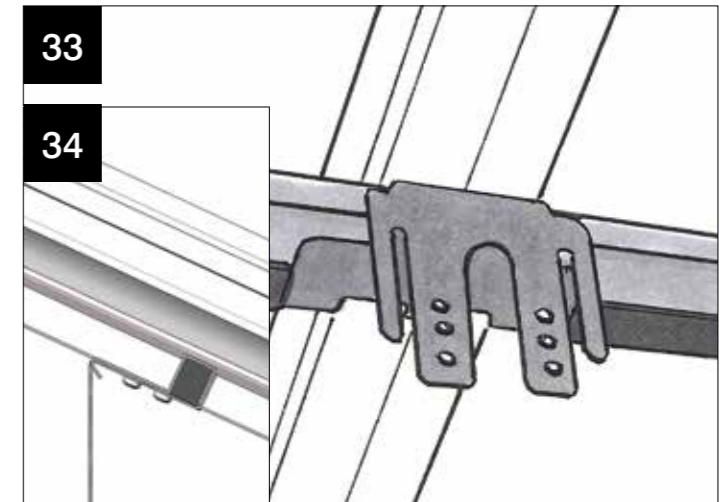

This is what you should see from the underside and the side view.

Now select the cloaking panel (polycarbonate) support trim for the remainder of the positions indicated in 31 in blue (E, F, H, I, J, K).

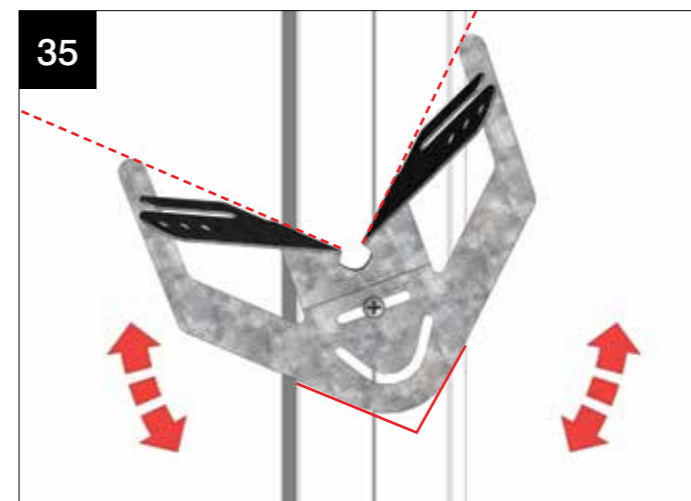

The hip bar bracket is free to rotate at the moment.

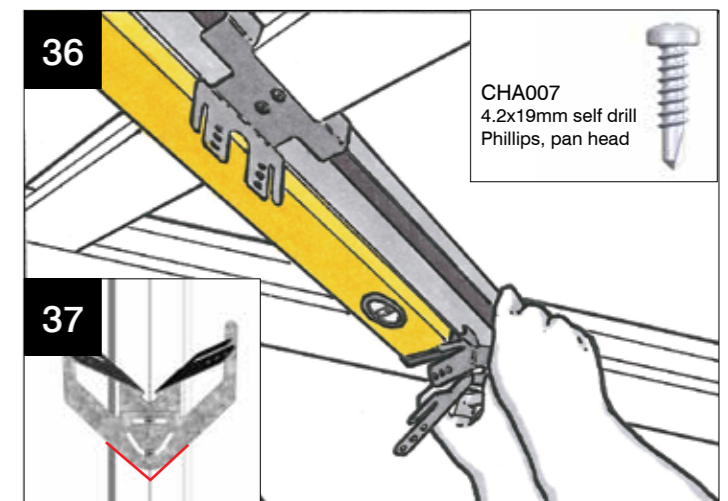

Using a long level butted up to the brackets on the transom bars adjacent, strike a line through to locate the final position. Tighten up the one previously fixed screw and add one more 4.2 x 19mm self drill Phillips pan head screw.

INSTALLATION - POLYCARBONATE CLOAKING PANELS

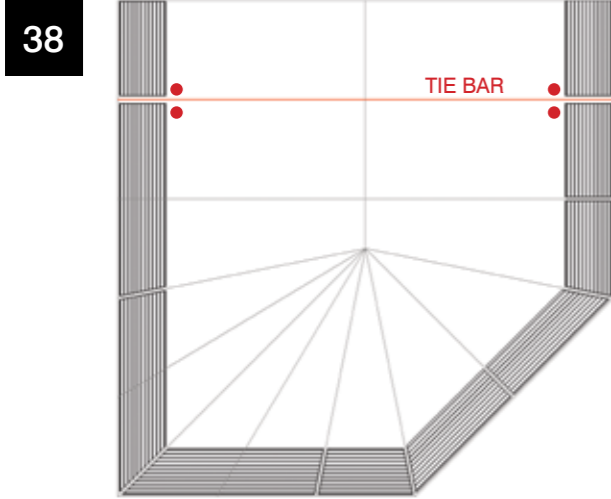

Now it is time to install the polycarbonate cloaking screen panels. See steps 41 - 42.

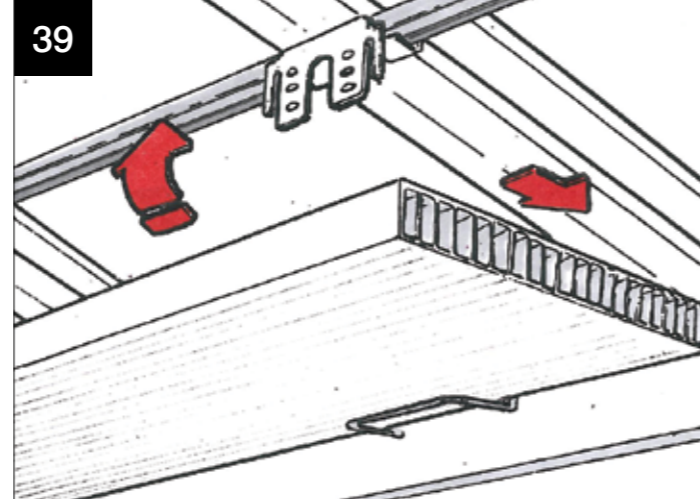

Referring to the location plan, take the appropriate piece of polycarbonate cloaking panel which lays parallel to the eaves. Next, 'sit' it into each of the support clips that are hooked over the fascia. Then push the polycarbonate up into the roof.

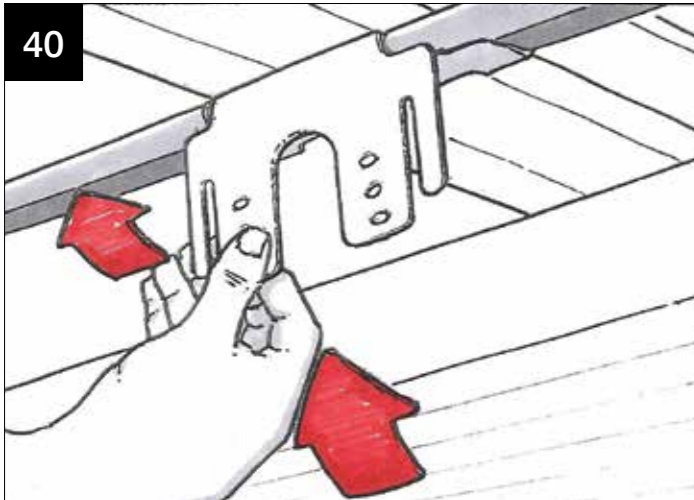

As the polycarbonate is swung into position, the transom brackets may need to be bent slightly backwards to allow the polycarbonate to clear them.

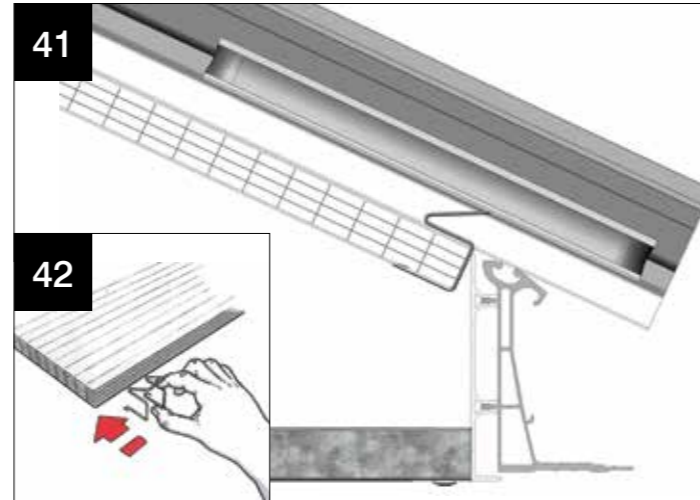

On glazing bars featuring tie bar brackets or those with bolsters, use CHA004 attached to the polycarbonate (acts as a spacer). See step 38 and '●' symbol shows where they are fitted.

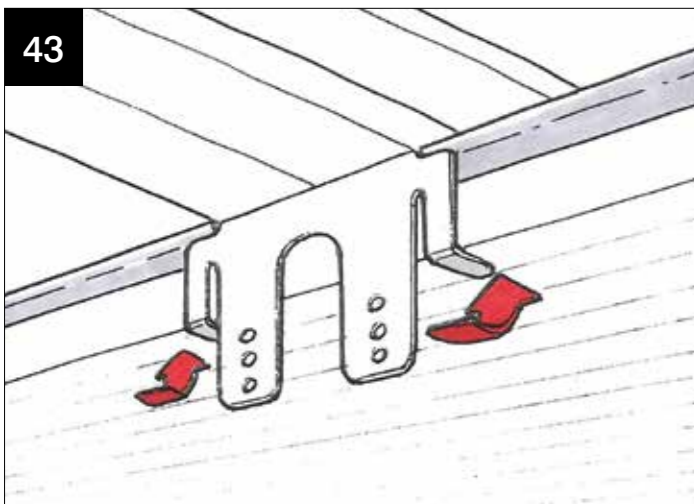

Next bend back the long legged tabs to hold the polycarbonate cloaking trim in its final position.

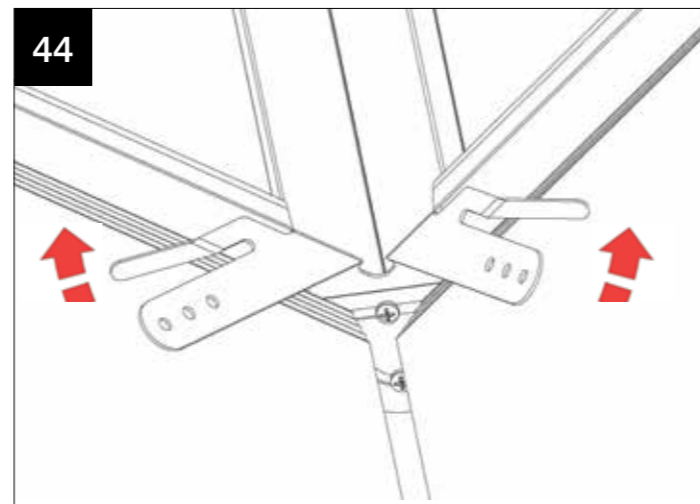

Undertake the same task on the Georgian brackets – ensure the polycarbonate cloaking panel is secured each side of the hip.

INSTALLATION - HORIZONTAL LADDERS

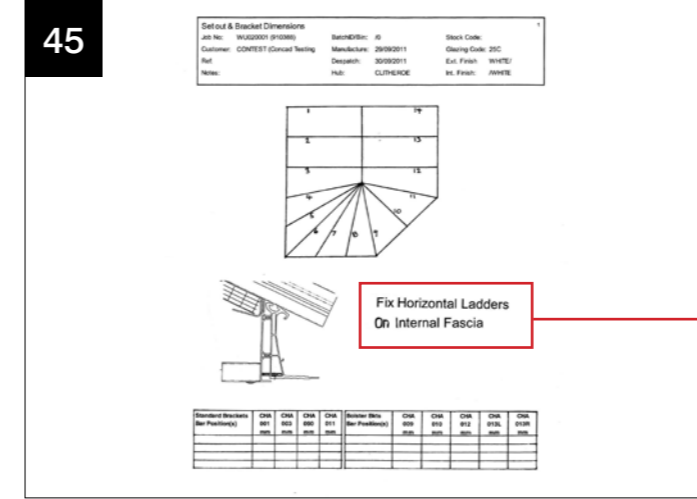

IMPORTANT NOTE: Now check on the 2 page location plan whether the horizontal frame is for 'on fascia' fixing (see 46) or 'below fascia' fixing (see 47).

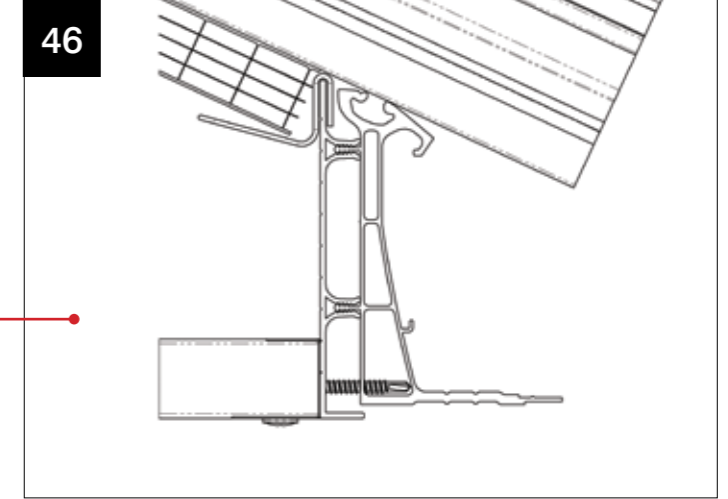

ON FASCIA

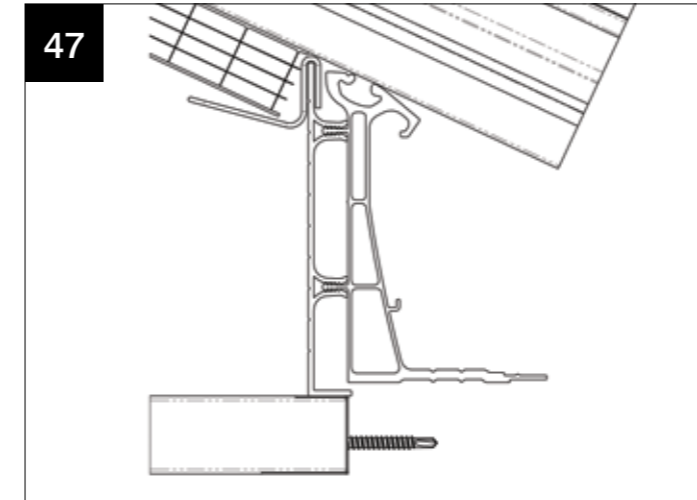

BELOW FASCIA

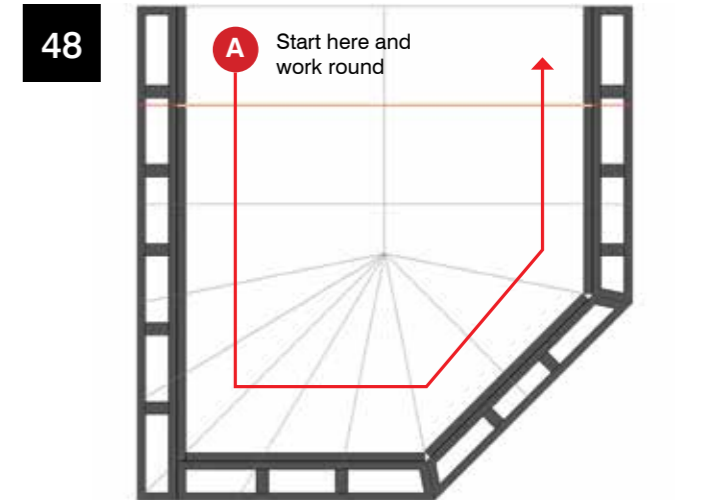

Refer to the location plan and always start from position A.

- All ladders are labelled with the same number as the eaves beam they are attached to (from the location plan),
- Then they have a V or a H depending whether they are a Horizontal or Vertical ladder,
- If the ladder is split into pieces due to the ladder going over length, or being split by bolsters, tie-bars etc then they additionally labelled with an "a", "b", "c", "d", ...

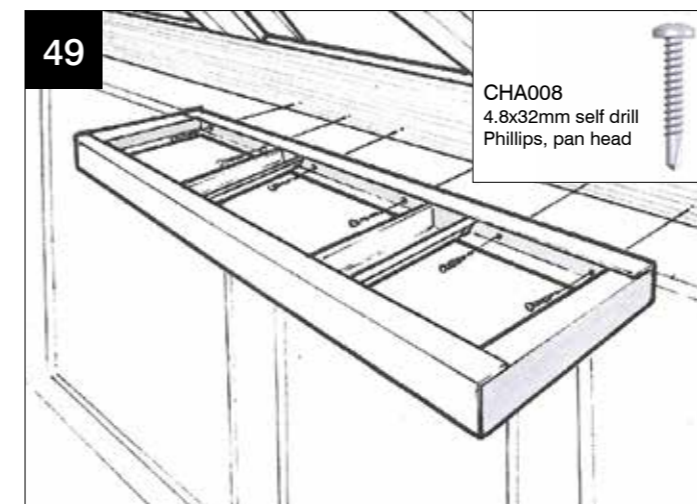

Offer up the first horizontal ladder- An adjustable support prop will help you here. Use two fixings 4.8 x 32mm CHA008 at 250mm centres into pre punched holes to attach the ladder.

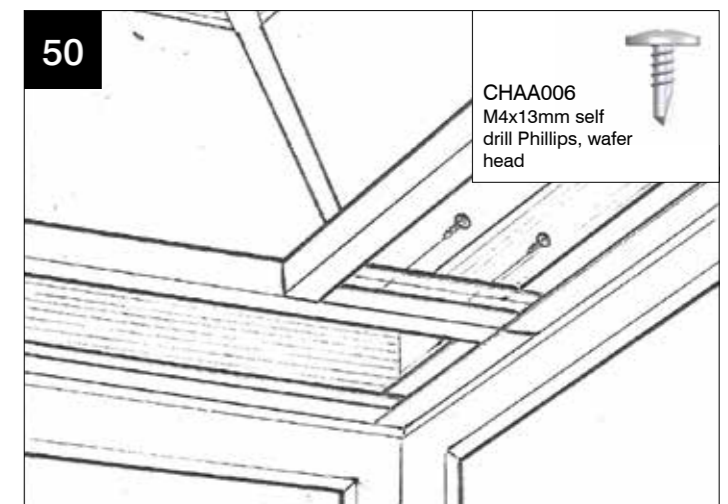

To attach two horizontal ladders at the corner use two fixings M4 x 13mm per butt joint.

INSTALLATION - VERTICAL LADDERS

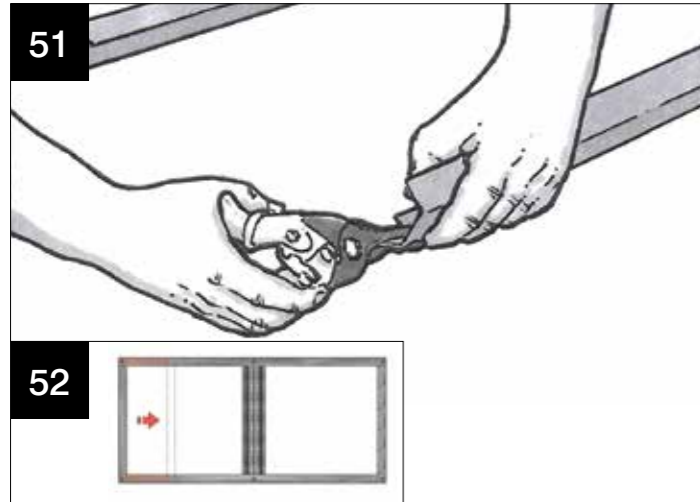

If it is necessary alter length of frames, simply remove end rail, trim with tin snips and reconnect.

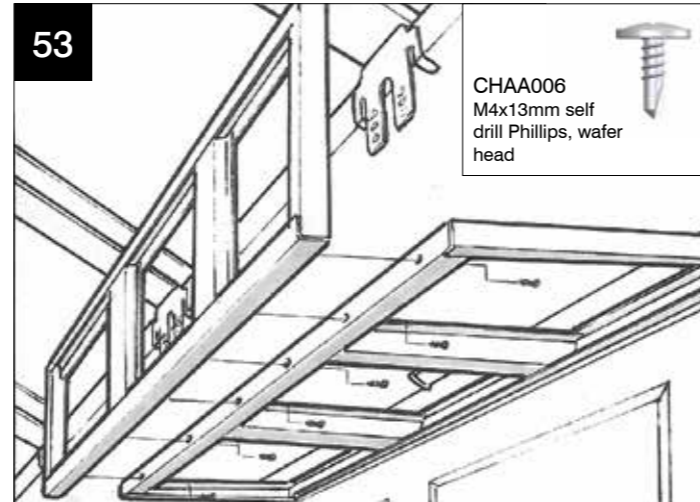

Using the location plan, choose the matching vertical ladder and offer it into position – hold firmly whilst attaching to the matching horizontal ladder using M4 x 13mm fixings, at 250mm centres into pre punched holes. Ensure the vertical ladder is behind the brackets.

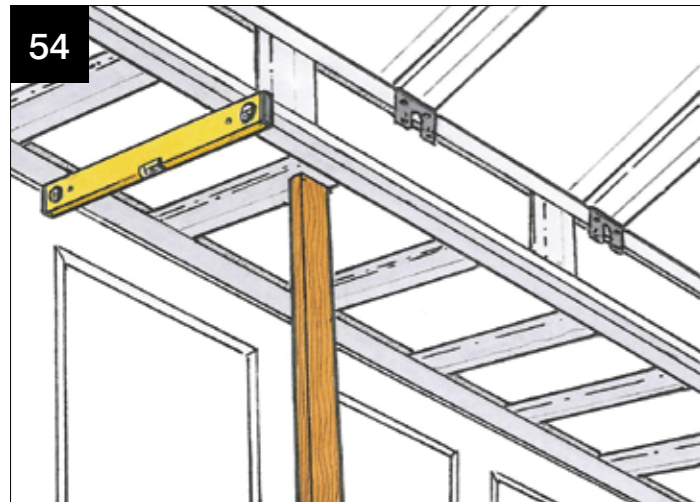

Undertake a final check that all is plumb, level and true.

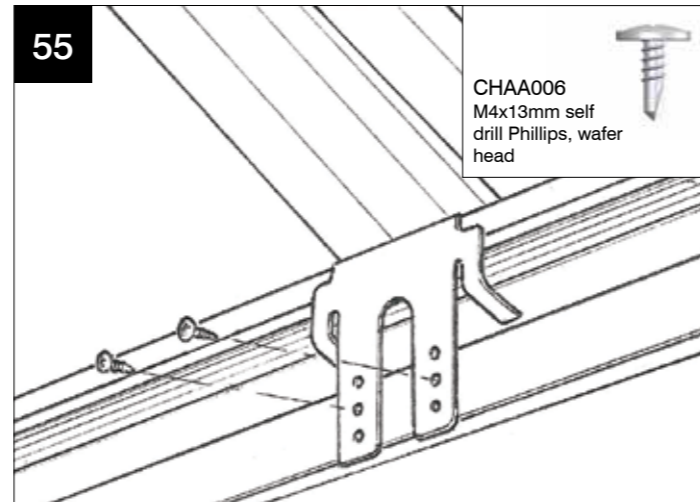

For each transom bracket use two M4 x 13mm fixings – the layout of the ladders should help you choose which of the three fixing positions to choose from.

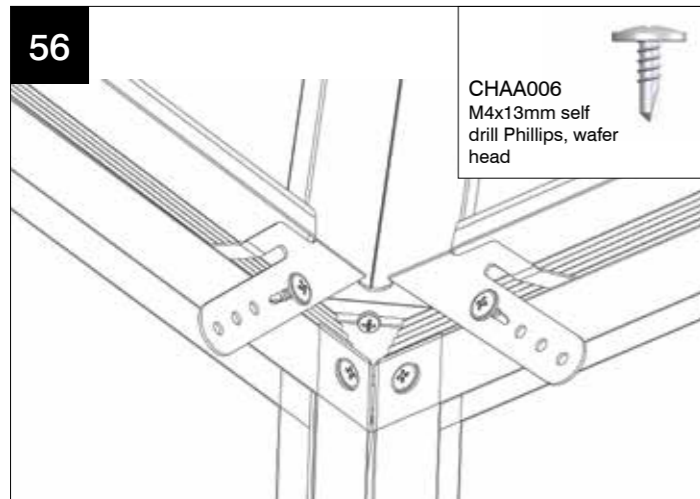

On the Georgian bar, use one fixing per side to fasten the bracket to the vertical ladder – use M4 x 13mm fixings.

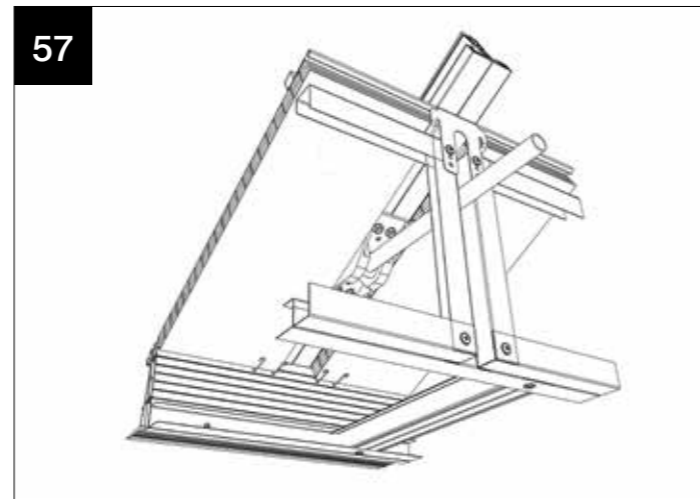

This is the arrangement around tie bars.

INSTALLATION - OTHERS

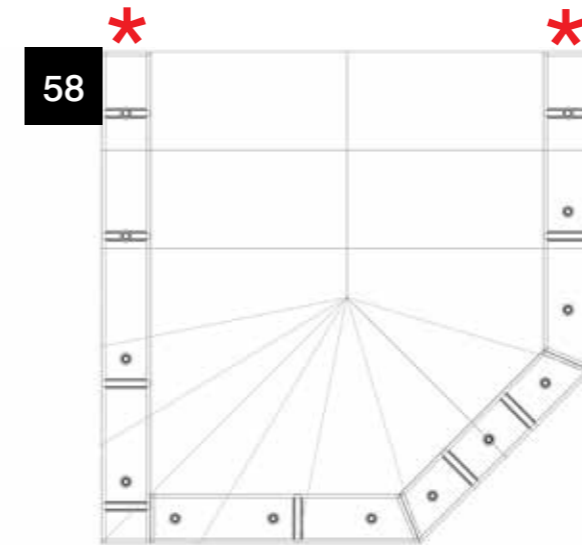

*** IMPORTANT NOTE:** Before applying 12.5mm foil backed plasterboard to ladder framework ensure horizontal and vertical ladders are fixed back to host wall. Finally, check lighting positions and adjust horizontal ladders to suit see step 59.

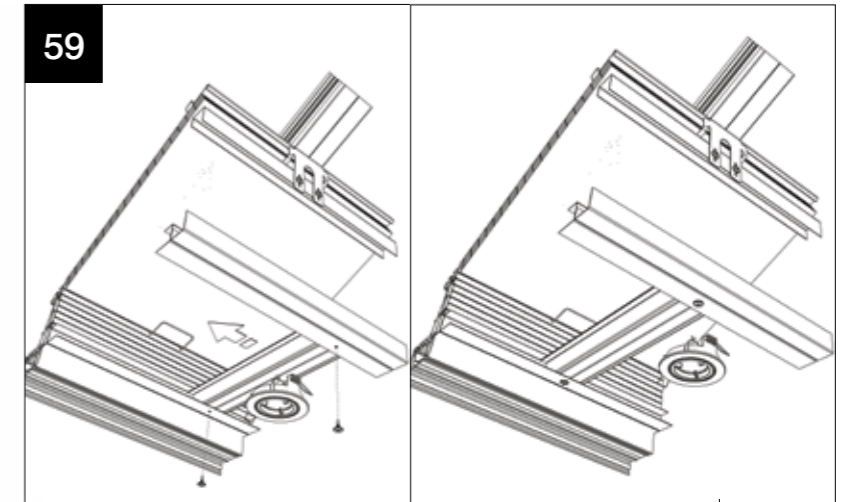

If a spotlight clashes with a cross rail, simply unscrew the cross rail and relocate as close as possible to the original location. Spot light no longer clashes as horizontal ladder is re-configured on site.

All electrical work must be carried out by a qualified electrician and tested in accordance with current BS7671 IEE wiring. Only LED IC (insulation contact) fire rated downlights to be used.

PLASTERBOARDING & PLASTERING

Guidance is based on advice provided by the SITE BOOK available from www.british-gypsum.com or call 0844 800 1991 bgtechnical.enquiries@bpb.com

This guidance based on the use of Thistle Finishing Plaster and 12.5mm Gyproc Wallboard Duplex T/E which has an additional metalised polyester film to act as a vapour control membrane.

- Based on a 2mm skim finish. Temperature must be maintained above 5deg C until plaster is dry.
- Plaster skimming should always commence as soon as possible after the boards are fixed.
- Use thin wall beads attached with 'dabs' of plaster – to provide additional support during drying, attach with non-rusting nails, screws or staples
- Reinforce flat joints with Thistle ProTape 50 or FT100 – these are made from glass fibre and are self adhesive and fitted before plastering.
- Any gaps bigger than 3mm must be pre-filled and reinforced using Gyproc Joint Tape which is embedded in the first coat over each joint, where sufficient plaster is left under the tape to ensure good adhesion and then a second plaster application used. This method is better resistance to cracking than glass fibre tapes.
- Ensure all plasterboards fitted to the horizontal and vertical ladders are scrim taped to the host wall prior to plastering.
- Apply Thistle Finishing Plaster with firm pressure, build out to 2mm thickness in two applications and then trowel to a smooth finish.

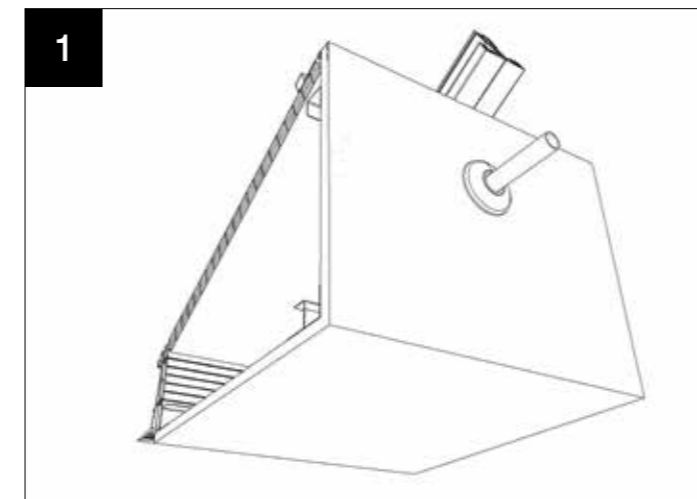

Once 12.5mm plasterboard is fitted, the tie bar rose (CHA005) flexes over the PVC conduit and should be spot bonded into position.

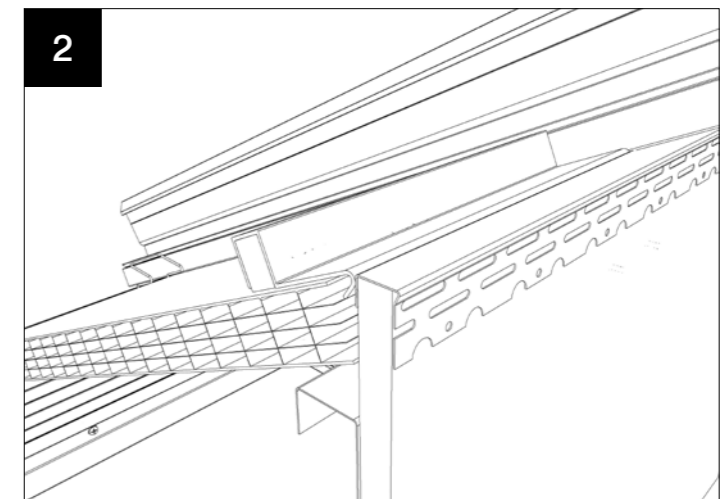

Ultraframe supplies a plasterers stop bead (CHA300) for the top edge adjacent to the glazing – ensure it is attached as shown. Be careful when handling/cutting this item not to damage the paint surface.

INSTALLATION - BOLSTER BARS

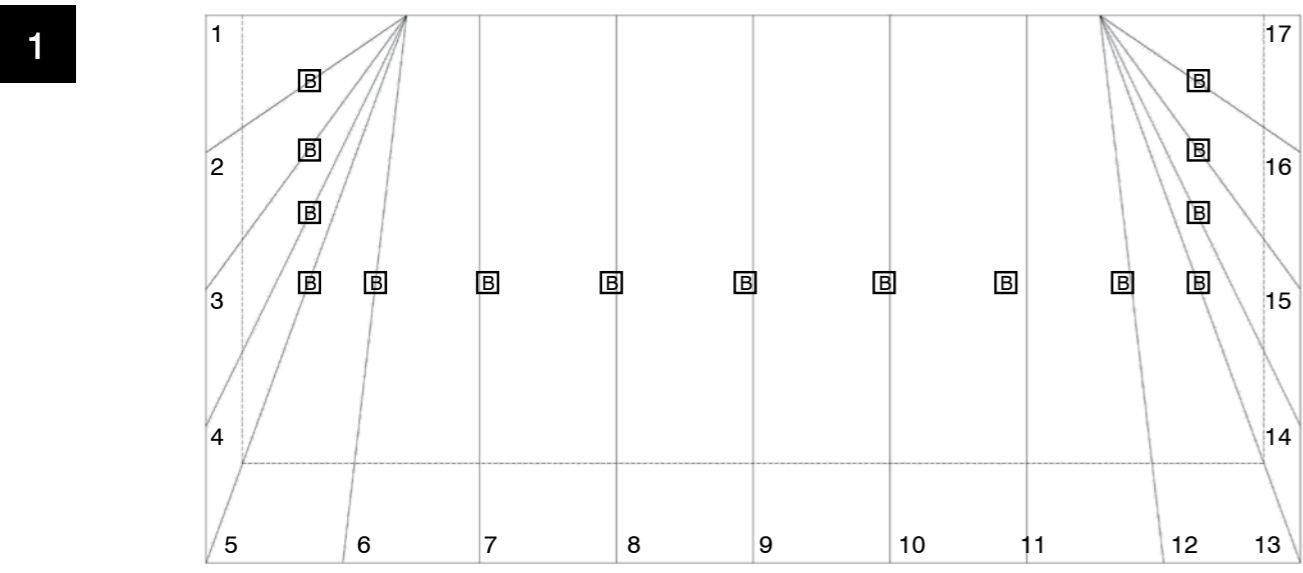

USE THE LOCATION PLAN TO FIND THE BOLSTER BAR LOCATION DETAILS

ROOF POSITION	STANDARD BAR BRACKETS POSITION (mm)				BOLSTER BAR BRACKETS POSITION (mm)				
	CHA001	CHA003	CHA090	CHA011	CHA009	CHA010	CHA012	CHA013L	CHA013R
1, 17	304								
2							228	-1	58
3							219	-4	115
4							216	0	178
5					Fit to suit		702	780	
6							699	34	-5
7, 8, 9, 10, 11					-26		728	728	
12							699	-5	34
13					Fit to suit		780	702	
14							216	178	0
15							219	115	-4
16							228	58	-1
	TRANS	ADJ HIP	ADJ HIP	SPLAY	TRANS BOTTOM	HIP	SPLAY BOTTOM	LEFT SIDE	RIGHT SIDE

EXAMPLE
Refer to separate location report

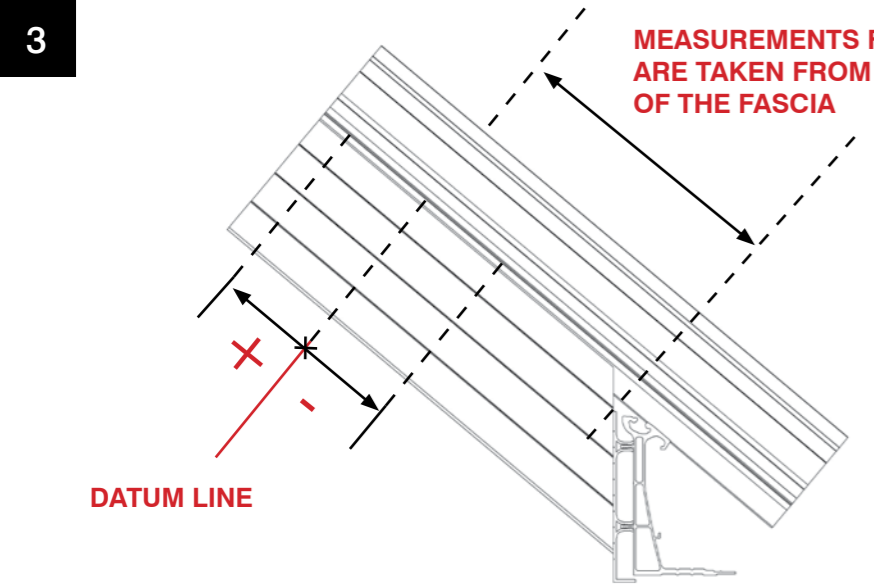

NOTE:
‘+’ Dimension towards ridge
‘-’ Dimension towards eaves

INSTALLATION - BOLSTER BARS - TRANSOMS

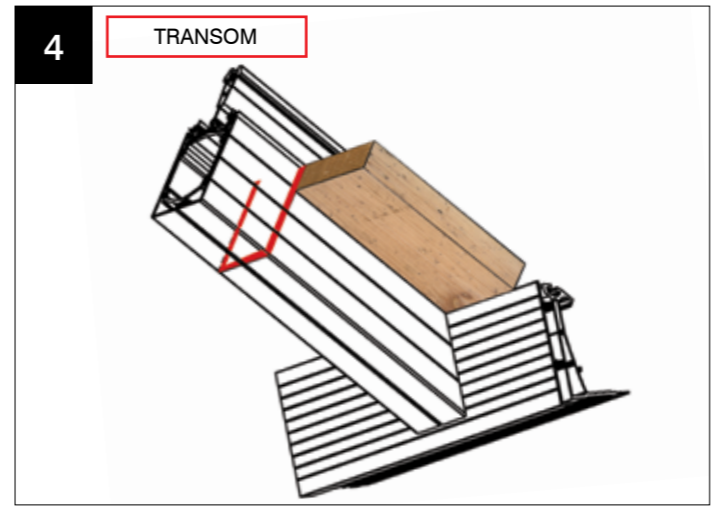

Using the location plan provided – see example in fig 1 - find the dimension for setting out bracket positions on the transom bars. Measure up the bar from the eaves beam, and mark the bolster cladding on all three sides. If your roof features many transom bars, it may be simpler to cut a piece of timber to length, to use as a template and mark using that.

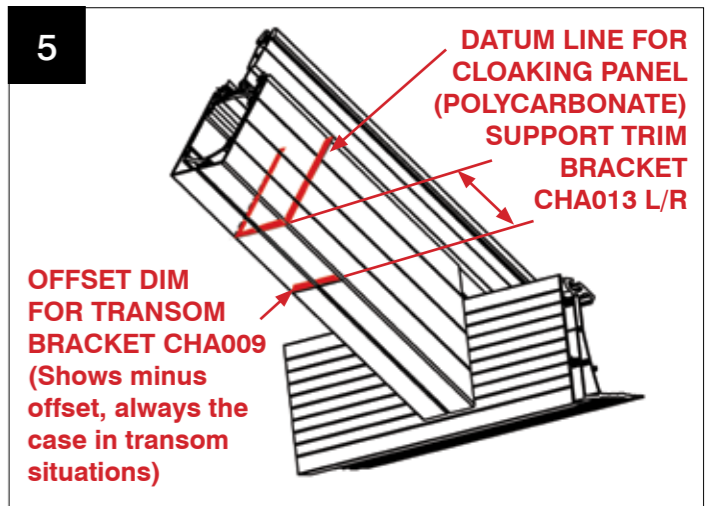

Using the bolster set out data on the location plan, mark each of the transom bars, for the bottom bracket using the offset dimension, always measuring down towards the eaves in transom situations.

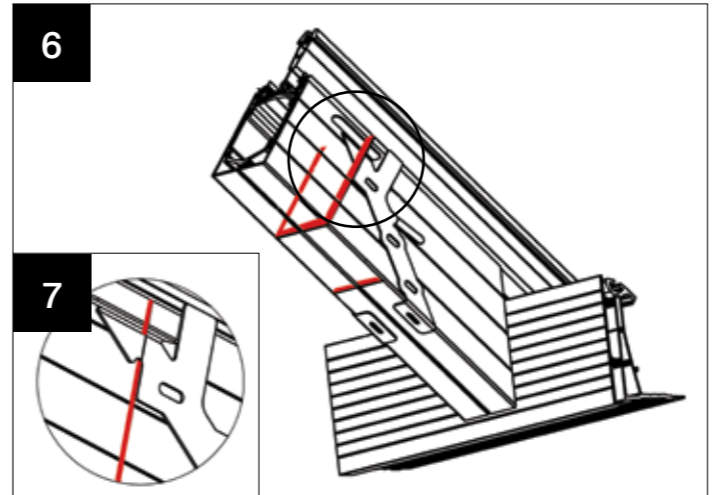

Take the bracket CHA013 L or R (fig 7) and line up with datum line (see inset diagram).

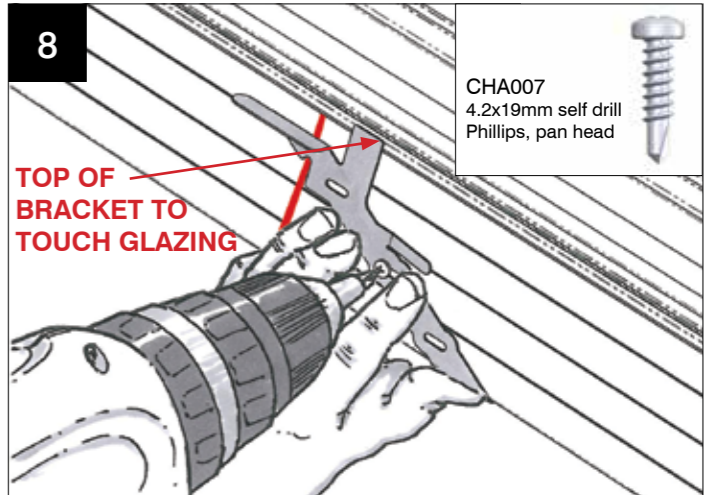

Now attach the bracket with a minimum of two CHA007 4.2 x 19mm self drill panhead Phillips screws. Repeat the process for the L (left) side bracket.

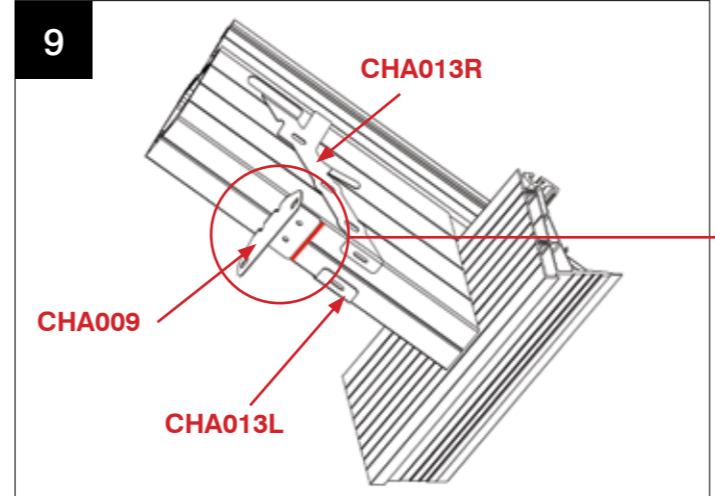

Then take the CHA009 transom bracket and line it through with the pre-marked minus offset dimension – see illustration alongside. Fasten with two CHA008 4.8 x 32mm self drill panhead Phillips screws.

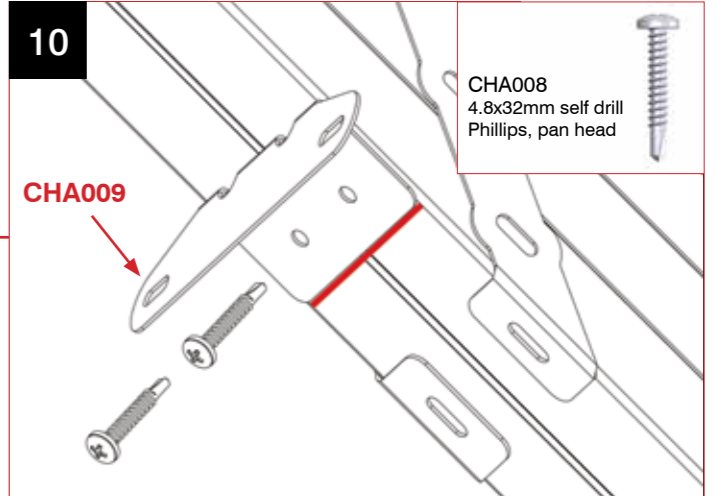

INSTALLATION - BOLSTER BARS - HIPS

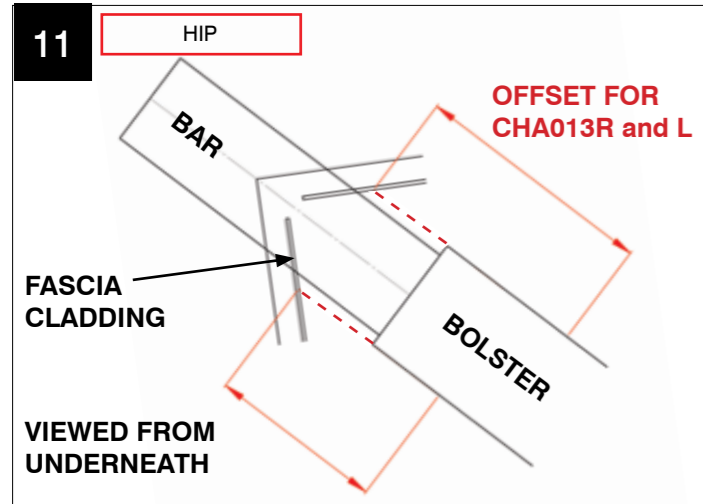

Looking from underneath the bolstered Georgian hip bar, strike a line down the side of the bolster cladding and put a datum line on top of the fascia.

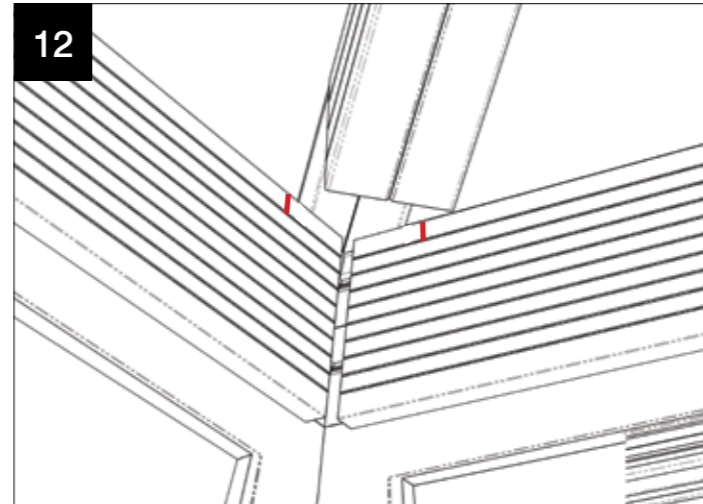

This is how it should look when you have marked each side of the eaves fascia with a datum point to measure from.

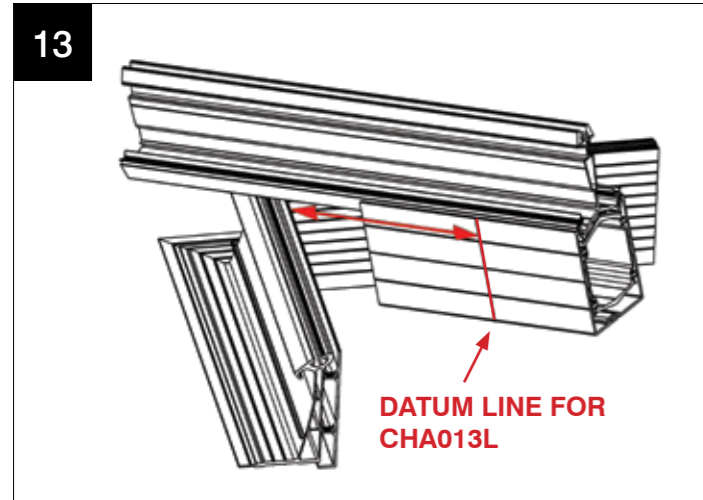

Now referring to the location plan, check the dimensions for left and right. Measure up the bar from the datum mark and mark both the side and face of the bolster cladding from the datum mark. Complete the task on left and right sides – the dimension may be different for each side.

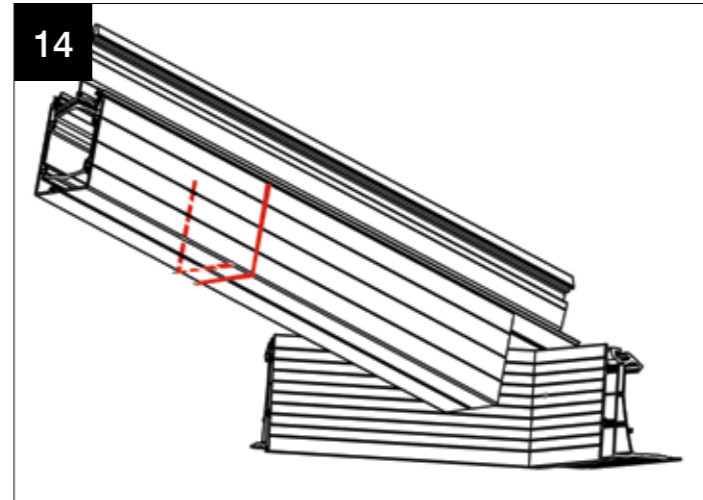

This is how it should look once you have measured and marked the hip bolster cladding.

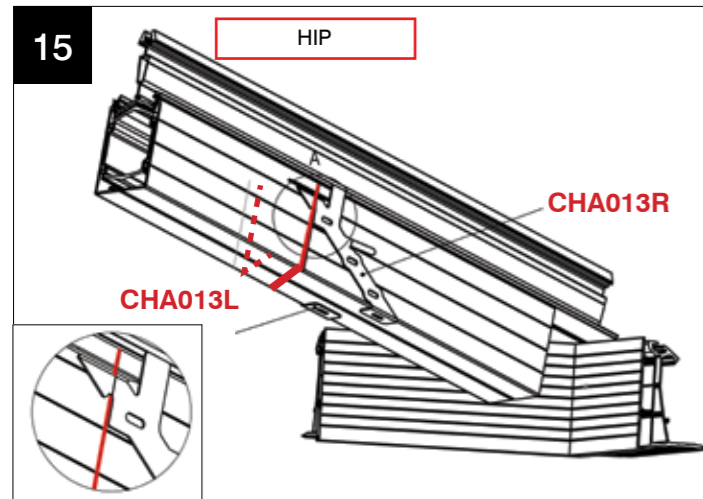

Take the bracket CHA013 L or R (right hand illustrated) and line up with datum line (see inset diagram).

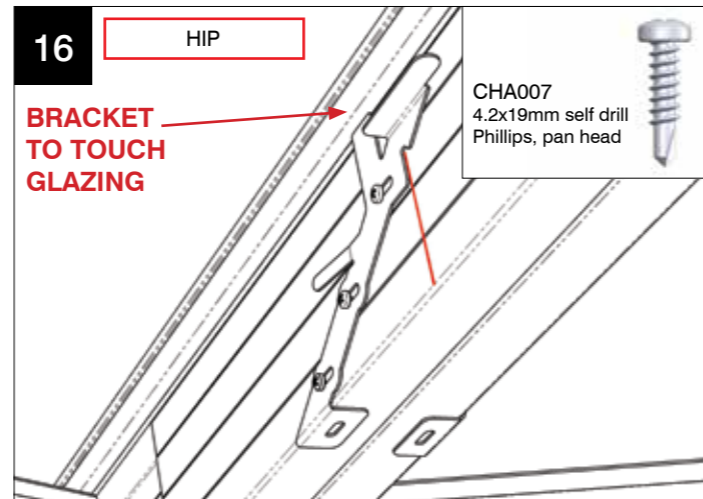

Now attach the bracket with a minimum of two CHA007 4.2 x 19 mm self drill panhead Phillips screws. Repeat the process for the opposite hand bracket.

INSTALLATION - BOLSTER BARS - SPLAYED

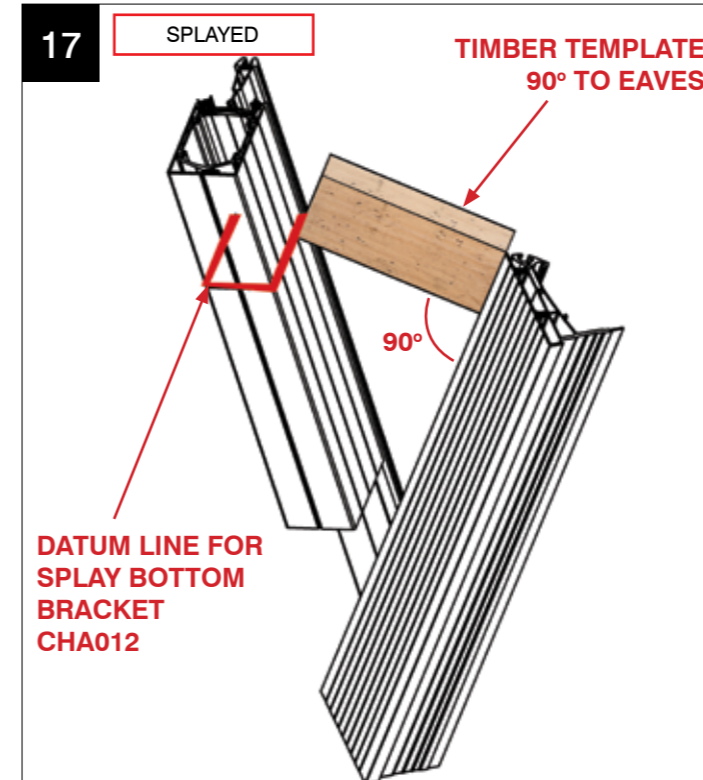

From the location plan, find the dimension for the splayed bar and cut a piece of timber to that length. Hold the timber along the top edge of the PFTB fascia board and then against the glazing. Mark a line all the way round the splayed bar cladding.

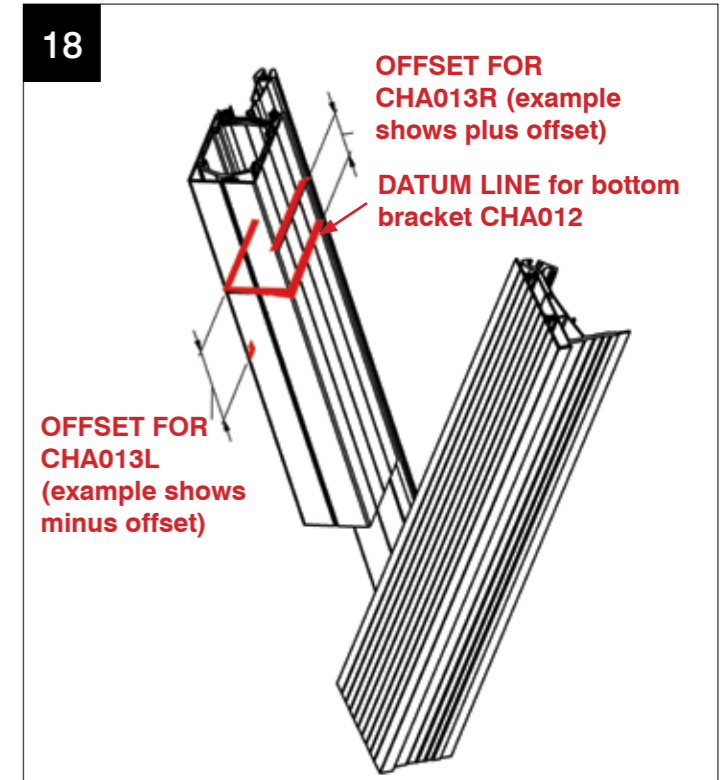

Using the location plan, measure and mark either the positive offset or the minus offset.

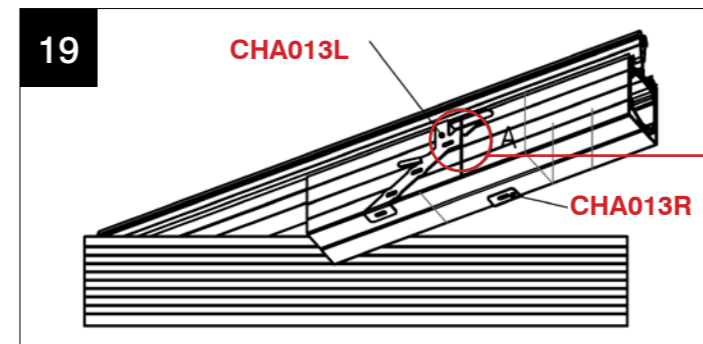

Take the bracket CHA013 L or R and line up with offset line. Now attach the bracket with a minimum of two CHA007 4.2 x 19mm self drill panhead Phillips screws. Repeat the process for the opposite hand bracket.

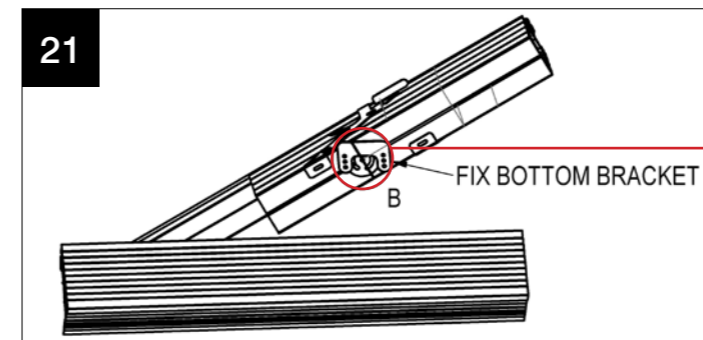
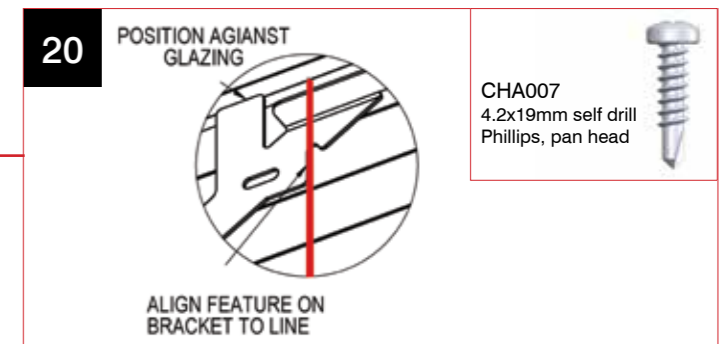

Then take the CHA012 splay bar bracket and line it up with the datum line – see illustration alongside. Fasten through centre hole with one CHA008 4.8 x 32mm self drill panhead Phillips screw.

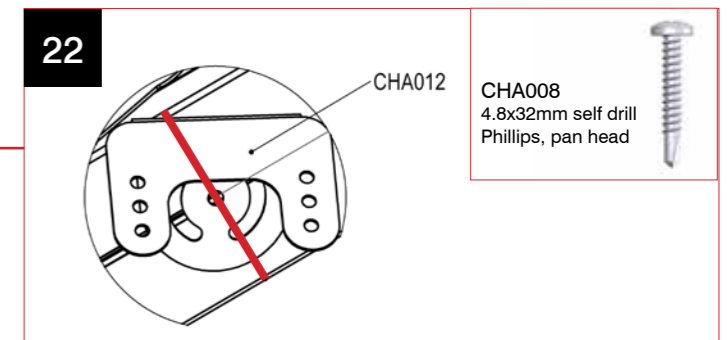

INSTALLATION - BOLSTER BARS

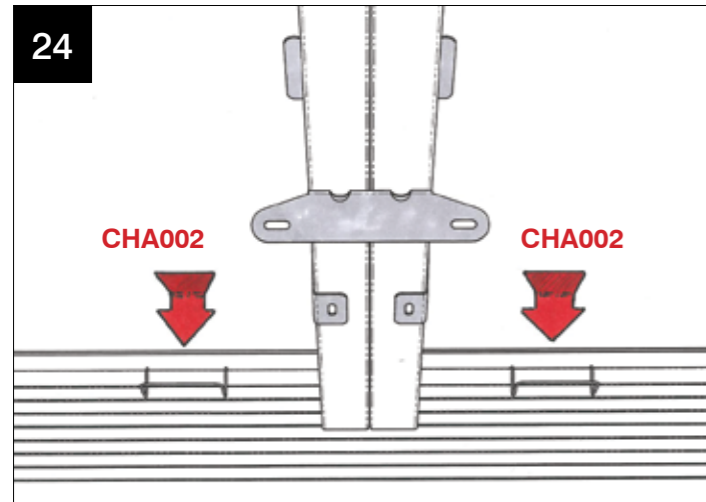
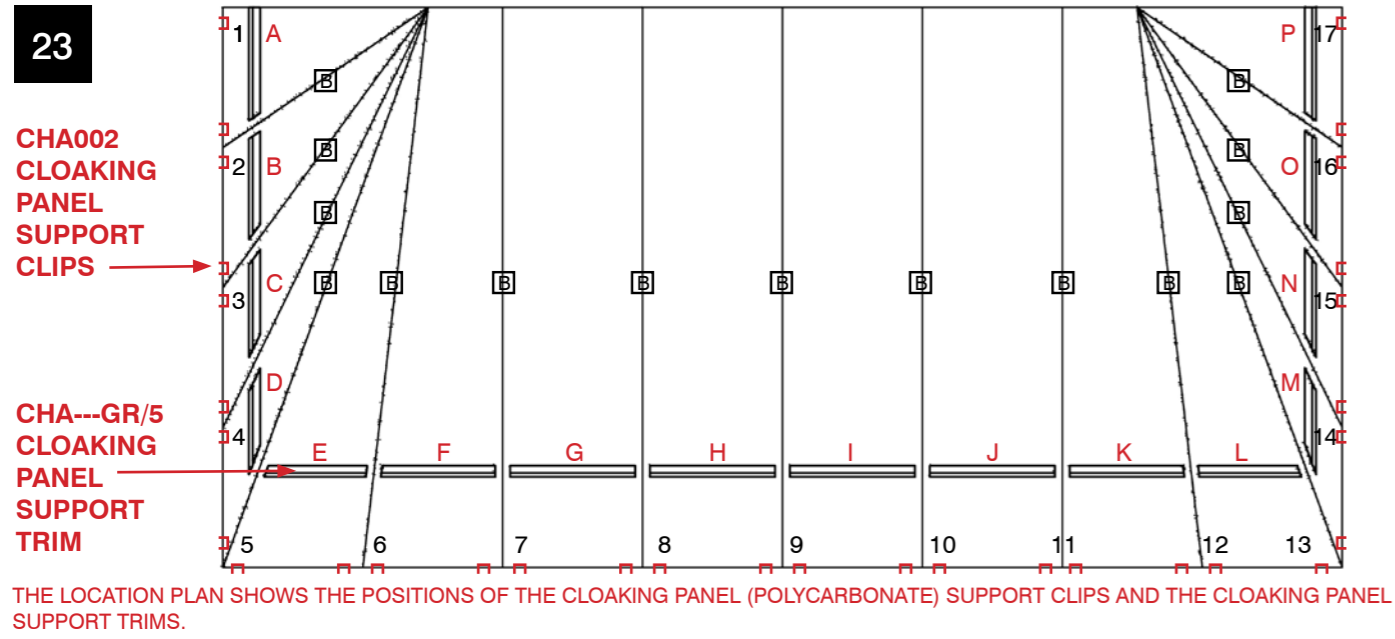

A cloaking panel (polycarbonate) support clip is placed each side of the transom bolster bars.

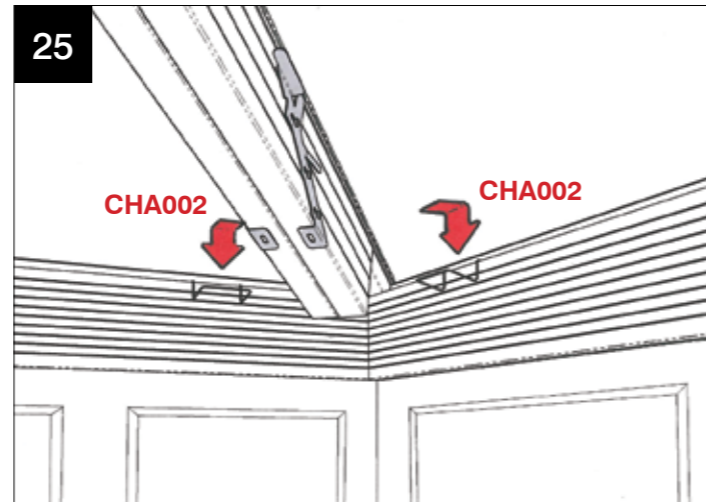

The support clips are located over the PFTB fascia board at hips and splayed bar positions too.

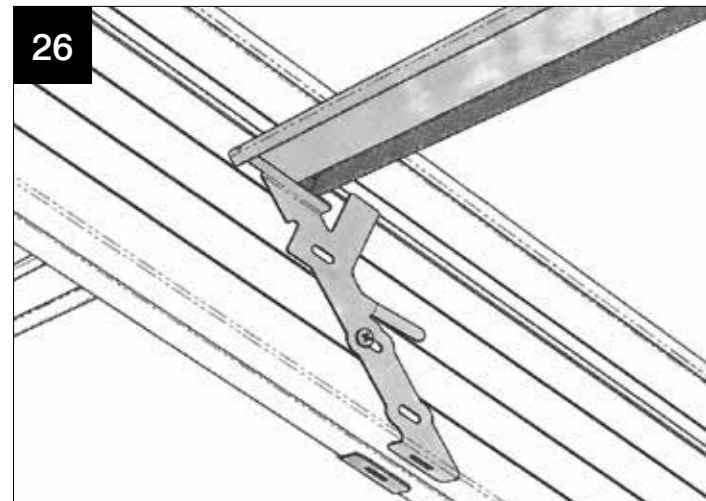

Offer into position the cloaking panel (polycarbonate) support trim – this is lifted up and over CHA013.

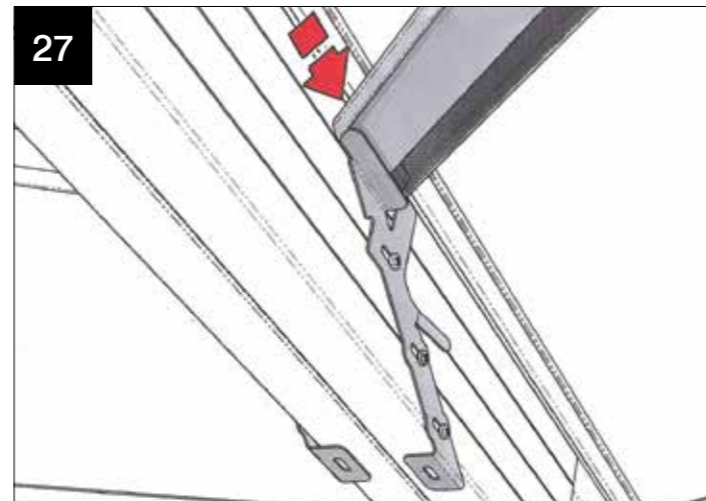

The cloaking panel support trim locks into position.

INSTALLATION - BOLSTER BARS

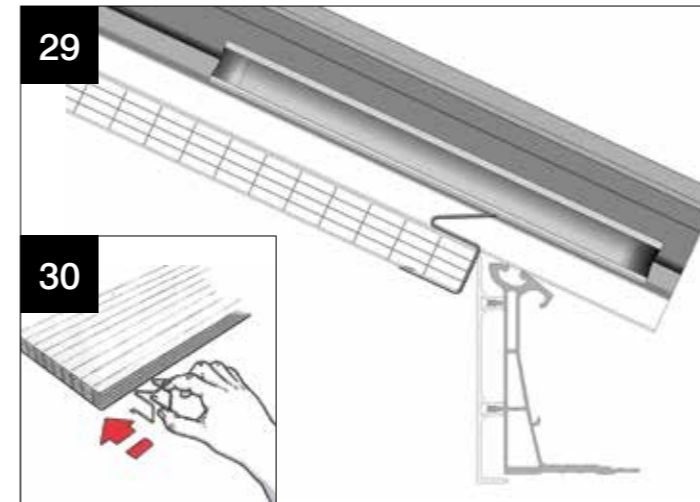

Now attach these polycarbonate support spacers CHA004 – attach to the leading edge of the polycarbonate (silver side up). Location plan and '●' symbol shows where they are fitted.

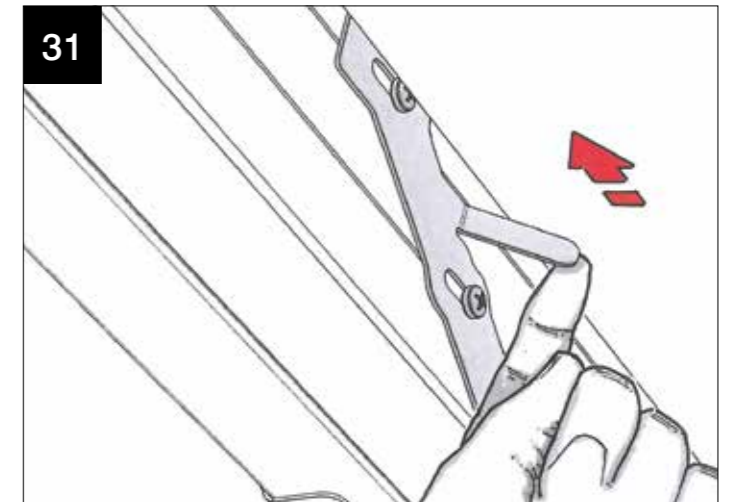

Fit the cloaking panel (silver side up) between the bolsters supported at the eaves by the support clips CHA002. Next bend back the long legged tabs on the CHA013 to hold the polycarbonate cloaking trim in its final position.

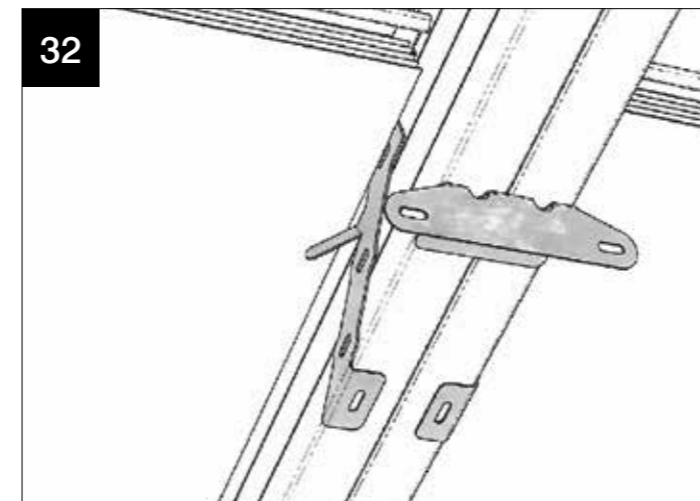

This is how the transom bolster bar should look at this stage.

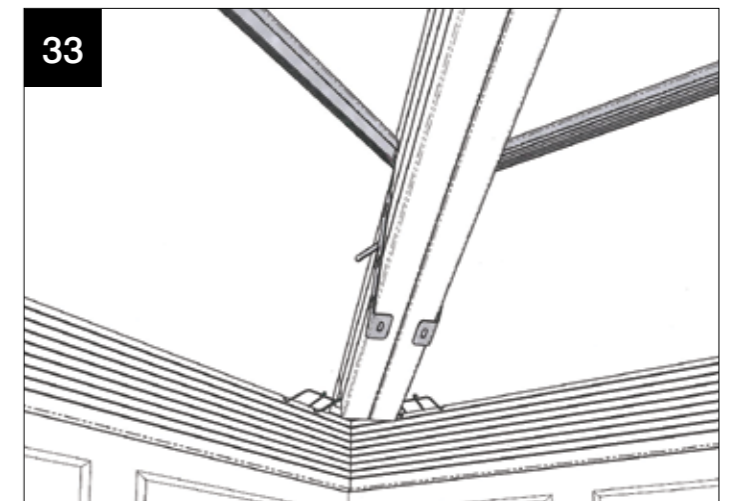

And this is how the Georgian bolster bar should look too.

INSTALLATION - BOLSTER BARS

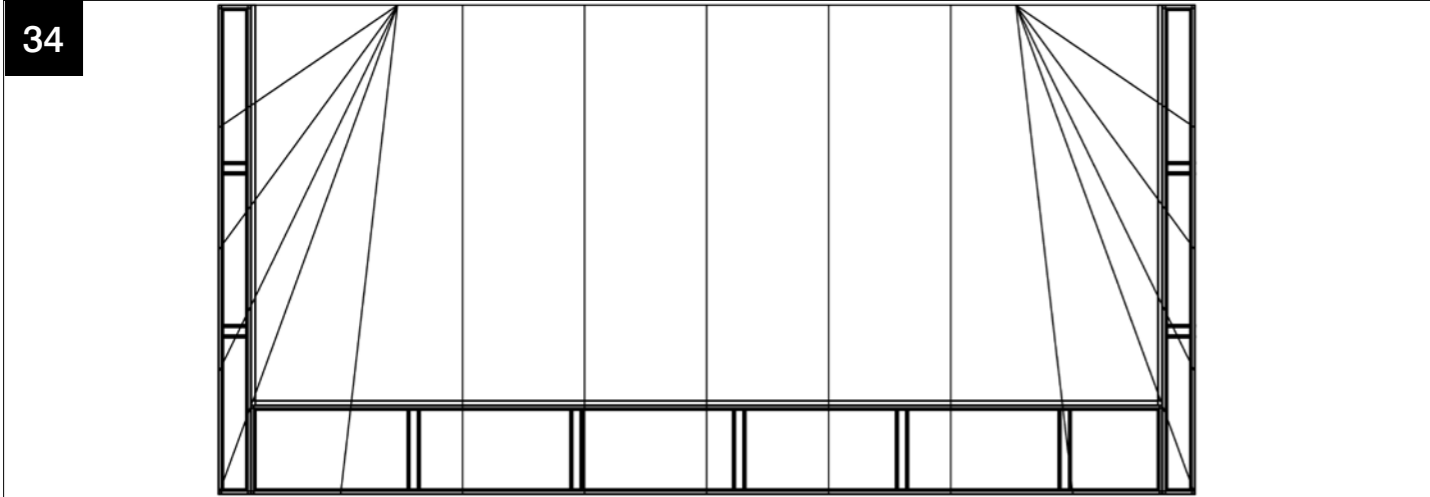

IMPORTANT NOTE. NOW CHECK ON THE LOCATION PLAN WHETHER THE HORIZONTAL FRAME IS FOR 'ON FASCIA' FIXING OR 'BELOW FASCIA' FIXING – SEE MAIN GUIDE PAGE 17, STEPS 46 AND 47.

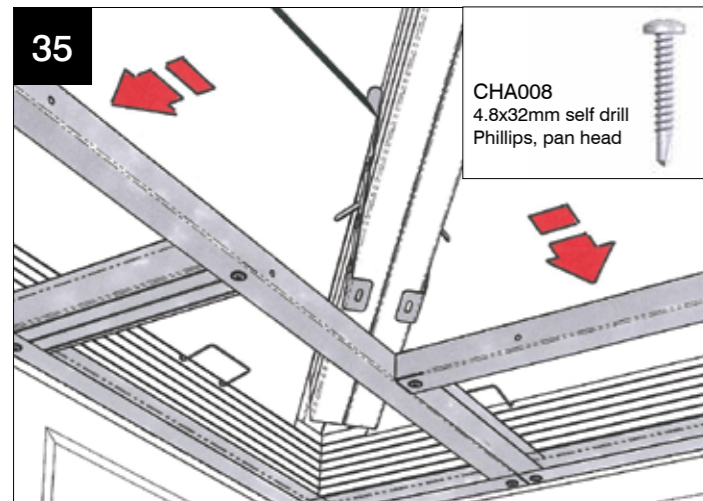

Having referred to the location plan, offer up the first horizontal ladder – a temporary timber support leg will help you here. Use 4.8 x 32mm at 250mm centres into pre punched holes to attach the ladder. Connect horizontal ladders together using two CHAA006 fixings. Add adjacent horizontal ladders.

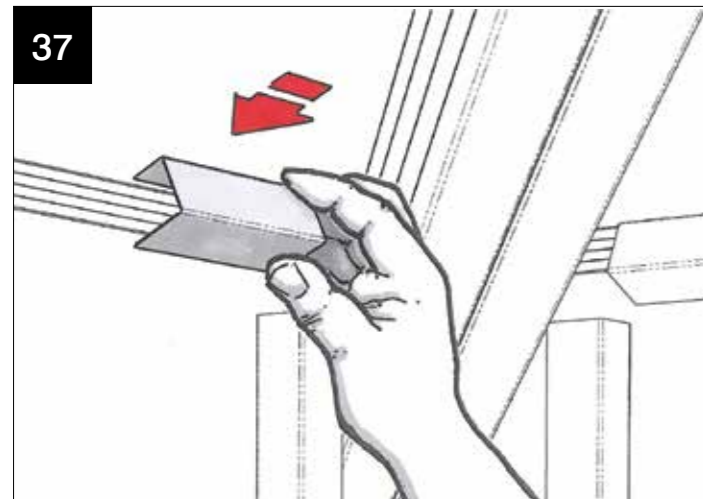

Now take the two 100mm pieces of fixing channels and slip over the two polycarbonate panels adjacent to the hip bar.

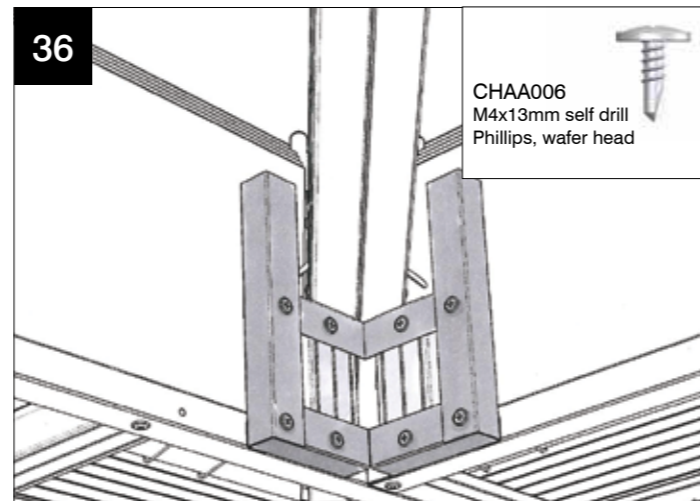

Unpack the bolster corner infill – it is supplied flat and needs to be unpacked and folded into a right angle. Taped to it are two 100mm fixing channels – place these on one side for later. Offer up the corner infill and screw through horizontal ladder into the back of the corner infill – use two CHAA006 M4 x 13mm self drill wafer head Phillips screws per side of the corner.

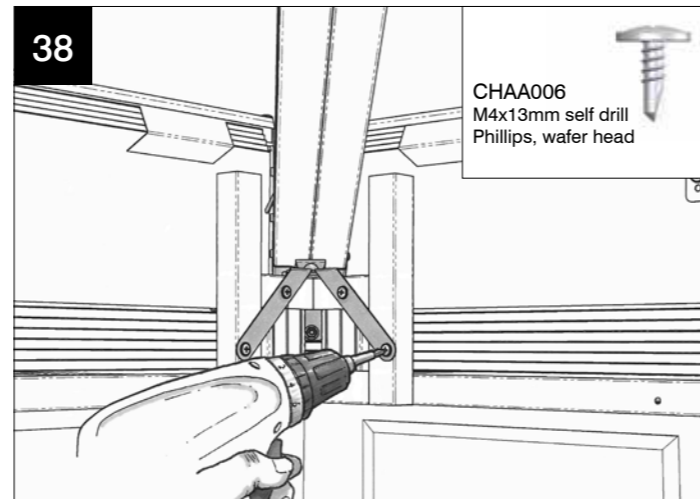

Next take the CHA010 hip bracket assembly and fasten the 'V' shaped element into the corner infill using 4 CHAA006 M4 x 13mm self drill wafer head Phillips screws.

INSTALLATION - BOLSTER BARS

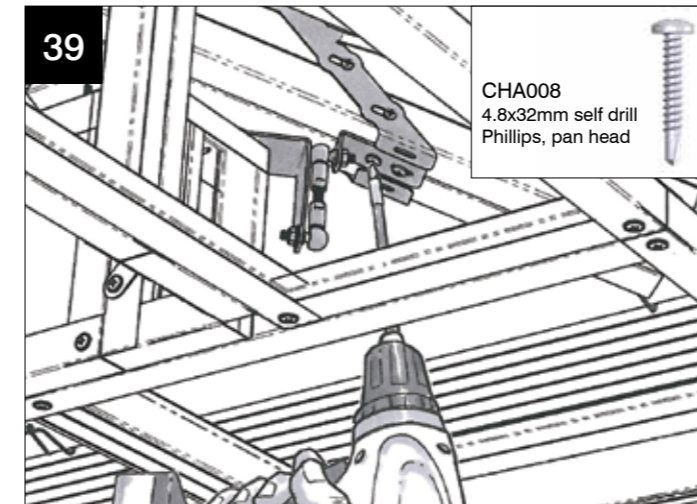

Now, screw up through the horizontal ladders to complete the assembly of the CHA010 hip bracket assembly using two CHAA008 4.8 x 32mm self drill panhead Phillips screws. Ensure horizontal ladders are level.

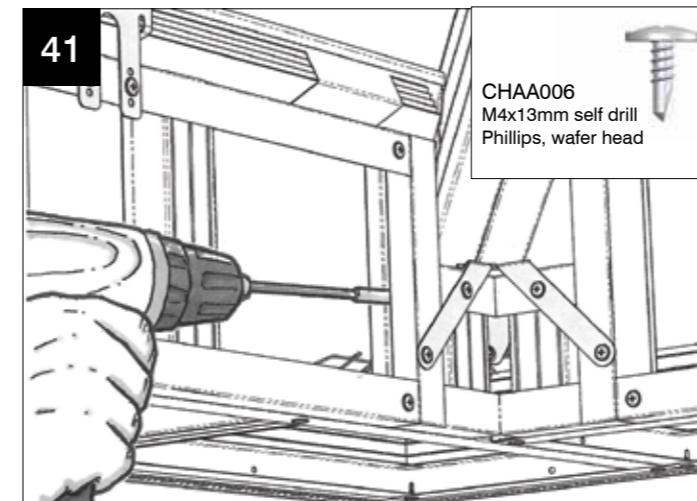

Butt the vertical ladder into the side of the corner infill – secure using two CHAA006 M4 x 13mm self drill wafer head Phillips screws. Use two per vertical ladder.

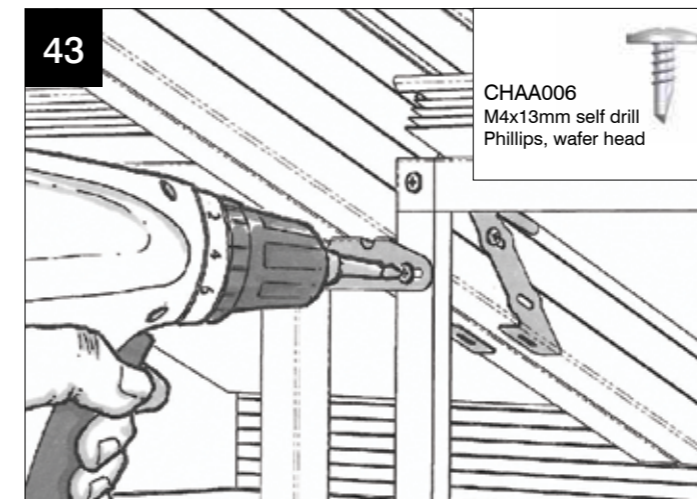

Secure the CHA009 bolster transom bracket at each side to the vertical ladder using CHAA006 M4 x 13mm self drill panhead Phillips screw.

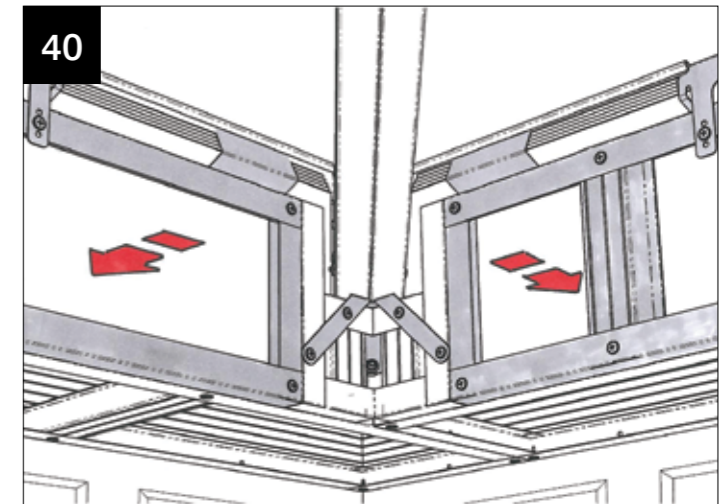

Using the location plan, choose the matching vertical ladder and offer it into position - hold firmly whilst attaching to the matching horizontal ladder using M4 x 13mm fixing, at 250mm centres into pre punched holes. Ensure the vertical ladder is behind the brackets.

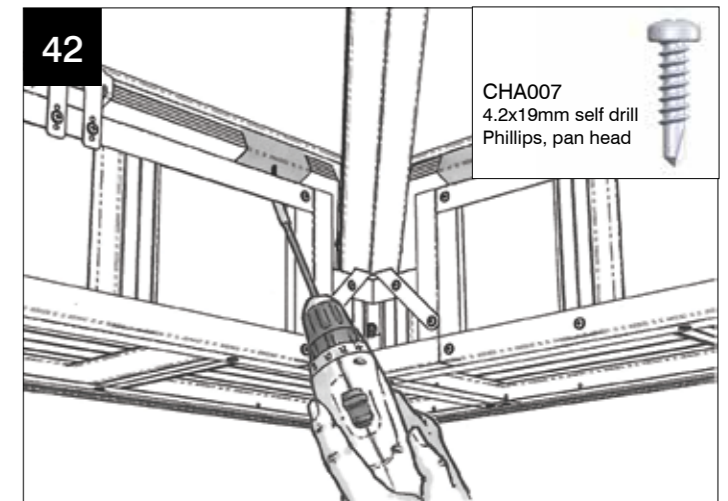

Now secure the top edge of the vertical ladder into the 100mm fixing channel – use two CHA007 4.2 x 19mm self drill panhead Phillips screws.

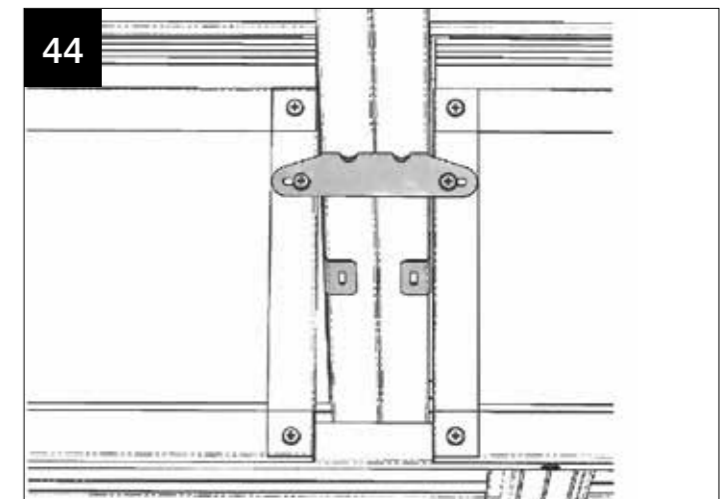

This is what the final transom bar should look like.

INSTALLATION - GABLE



GABLE BRACKET (left) CHA019L GABLE BRACKET (right) CHA019R.



1 Using the location plan provided find the dimension for setting out the clip positions for the gable brackets. Measure up the bar from top edge of the fascia board and mark it.



2 Take the gable bracket (CHA019R right hand shown). The back edge of the bracket should butt up to the pencil line. Align the top face of the gable bracket with underside of starter bar cladding.

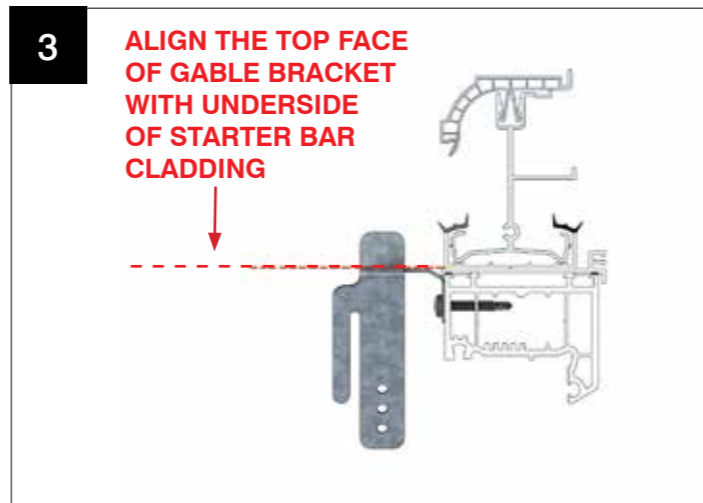

3 **ALIGN THE TOP FACE OF GABLE BRACKET WITH UNDERSIDE OF STARTER BAR CLADDING**
Attach gable bracket to frame using two of the CHA008 (4.8 x 32mm) self drill Phillips Pan Head screws supplied.



4 Offer into position the cloaking panel support trim - the nose of the closure trim must be notched back as shown (at the gable side only).



5a **NOTE: AREA MARKED ABOVE TO BE NOTCHED BACK.**

INSTALLATION - GABLE

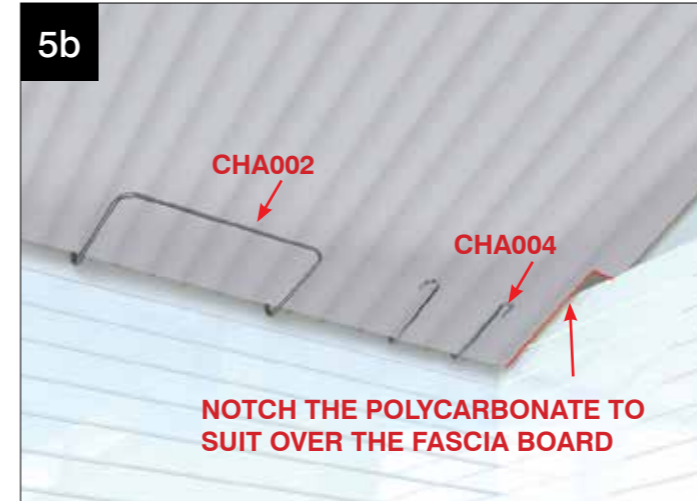

5b Referring to the location plan, take the appropriate piece of polycarbonate cloaking panel, mark and notch the corner as demonstrated.

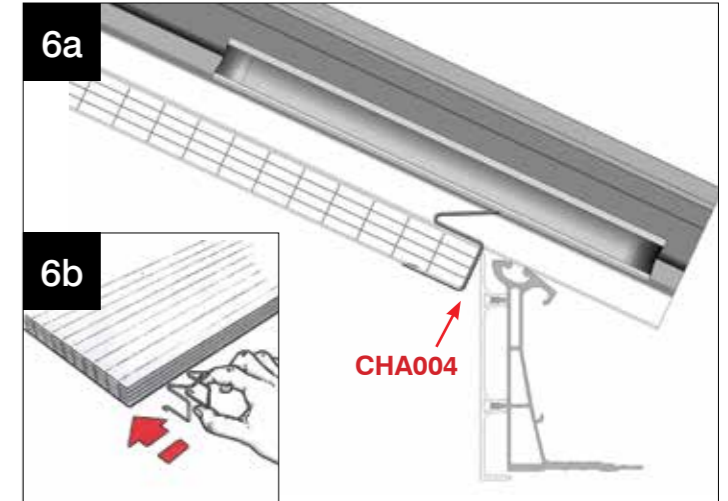

6a Attach CHA004 to the cloaking panel and fit as shown in the main internal insulated pelmet installation guide. (page 16).
6b









7 Fit the horizontal and vertical frames as shown in the main internal insulated pelmet installation guide. (pages 17 and 18).



8 Fix the vertical frame into the fascia board using 2x CHAA006 (M4 x 13mm) self drill Phillips, wafer head screws (supplied).

INSTALLATION - VALLEY

VALLEY BRACKET KIT CONTENT CHA014				No. Req
	Valley Fixing Plate	CHA016		x1
	WSR 4.8x70 Z Self Tapping Drill Point	CHA017		x2
	200x100x27x2.5 Thick Galvanised MS Strap	CHA018		x1
	Bag of 25 - M4 x 13 Self Drill Philips Wafer	CHAA006		x1
	Poly Panel Spring Clip	CHA002		x4
	Poly Support Wire Form Bolster Spacer	CHA004		x2

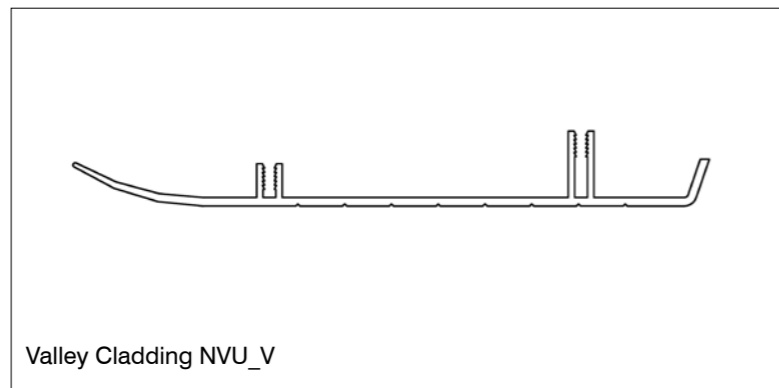

NOTE: The transom bracket CHA001 **MUST** be trimmed and adapted to suit situations where a transom bar, valley and internal insulated pelmet vertical frame intercept, as shown above.

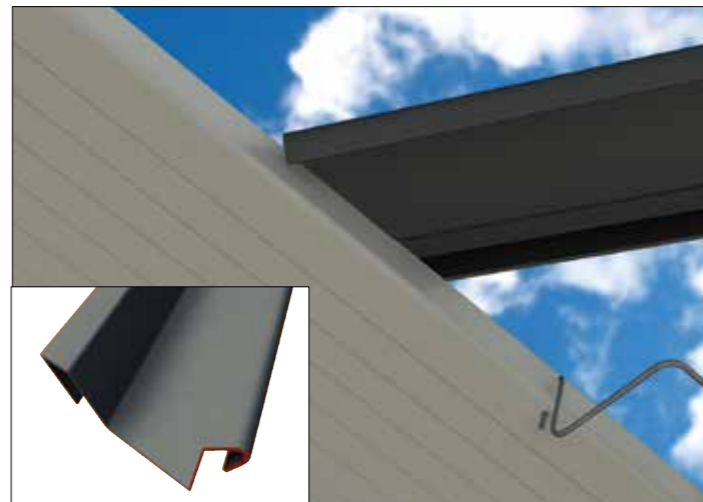

In valley situations the closure trim sits onto the valley drip profile. The nose of the closure trim must be notched as shown above, this allows the trim to sit flat.

INSTALLATION - VALLEY



Mark out and cut the valley cladding and fix valley fixing plate by following steps 1 - 5.



Using a level, plumb up off the horizontal frame and mark the outer bottom edge of the valley cladding on both sides (Mark "A").

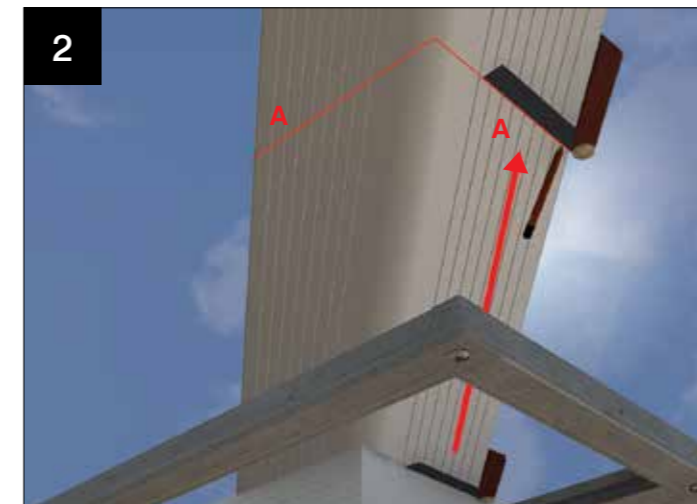

Using an angle finder (or joiners bevel). Draw a line on the valley cladding from the mark 'A' parallel to the eaves.

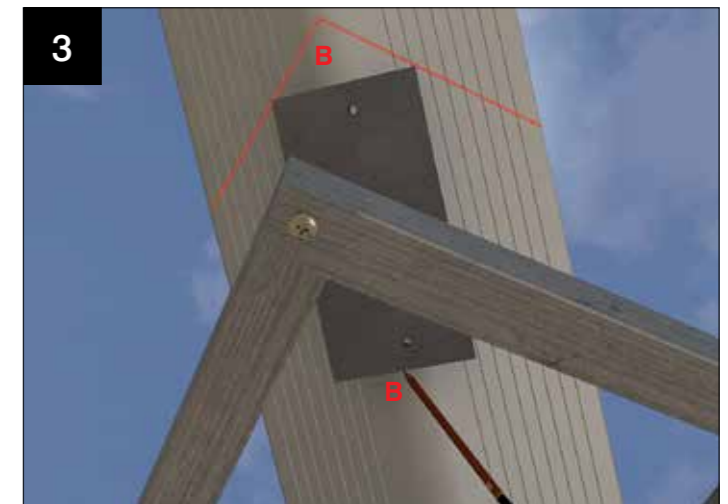

Temporarily position the valley fixing plate central of the valley with the top edges touching the marked lines. Mark either side of the plate (shown as 'B' on the cladding). Now remove valley fixing plate.

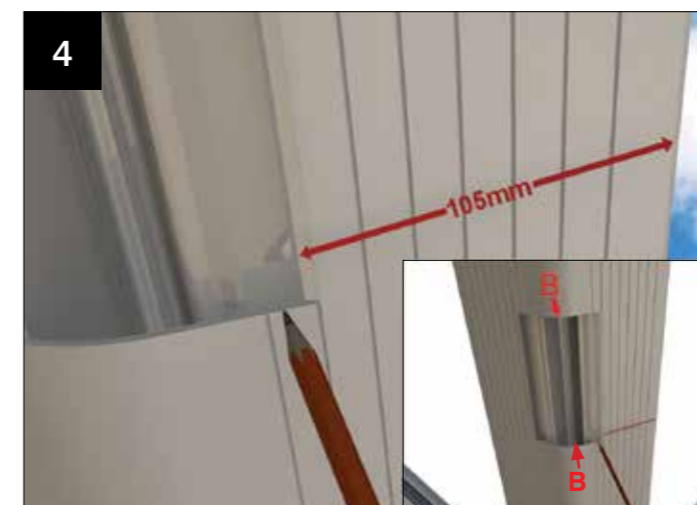

Then measure 105mm in from each side of the valley cladding and extend mark B top and bottom to form pencil rectangle. Cut out valley cladding.



Fit valley plate as shown to the valley wing central connector using CHA017 (2x4.8x70 self tapping screws).

NOTE: FOAM SIDE POSITION TOWARDS THE VALLEY.

INSTALLATION - VALLEY

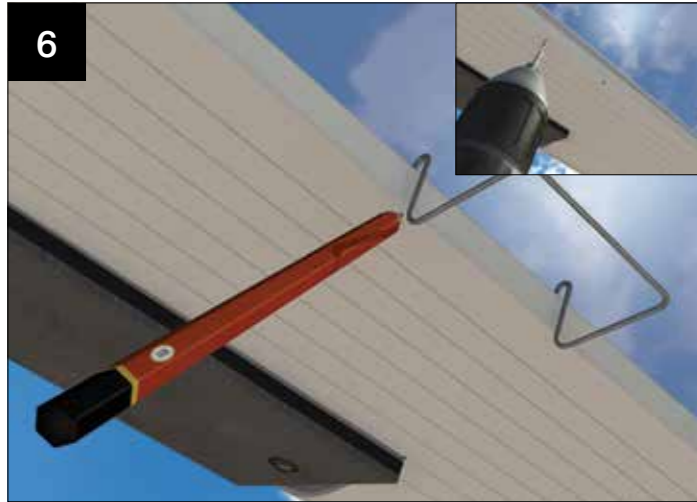

Fit the cloaking panel support clips CHA002 onto the valley cladding (2 per valley side supplied). Space out clips and temporarily hook over the valley cladding. Mark the leg positions then remove the clips. Drill a 5mm hole at each leg position as shown. **NOTE: AVOID DRILLING THROUGH THE VALLEY DRIP PROFILE.**



Refit the clips with the clip leg extending through the holes.



Attach the cloaking panels and fit as shown in the main internal insulated pelmet installation guide. (page 16).



Fit the valley corner infill panel to the horizontal frame, level up and secure to the valley plate.



FIT THE STRAP CHA018 USING M4x13 SELF DRILL SCREWS, to the valley corner infill panel and the valley fixing plate. It may be necessary to bend CHA008 to suit.



Fit the vertical frames. Fix the frames into the valley corner infill and the horizontal frames.

INSTALLATION - VALLEY



Using the bracket positions, level through and mark off the valley marked 'C'.



Measure and fit the standard valley undercladding NVU-V between the eaves and mark 'C'. Scribe to suit.

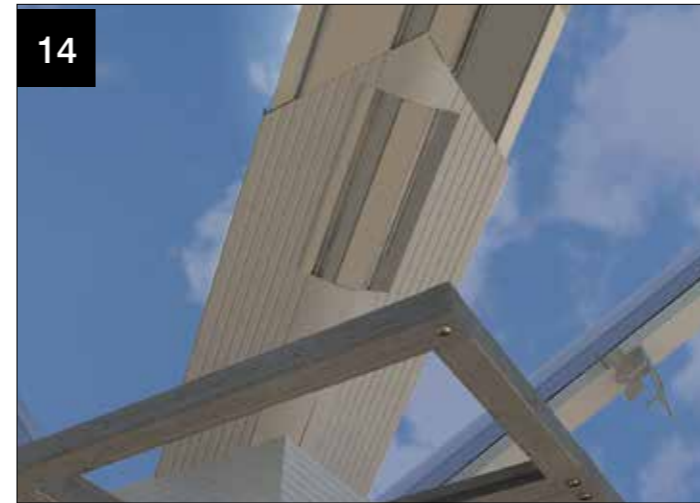

Fit the valley plate CHA016 (refer to steps 1-5, valley standard classic).



Valley infill panel fitted to horizontal frame, as image 10.

INSTALLATION - INTEGRAL BOXGUTTER

Quantal customers see bottom right



1 If not already fitted, attach box gutter insulation foam to the upper section of box gutter.

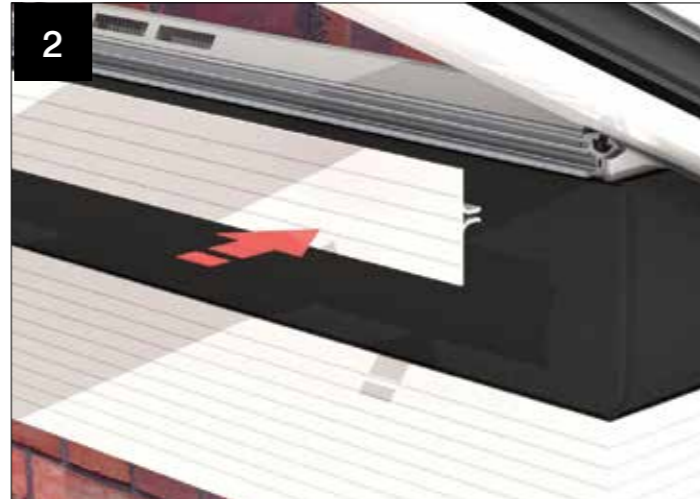

2 Fit length of LHE---/2 to the upper section of box gutter.



3 Using LHE---/2 as a datum, measure and mark the positions of the brackets in line with the dimensions given in the provided paperwork.



3a **FITTER TIP:** If possible, check and line through with the bracket position on the adjacent full length bar. Mark the bracket positions on the bars off the box gutter.



4 Fit brackets in marked positions on the bars as per standard installation and fit closure trims CHA--GR/5 according to layout plan.

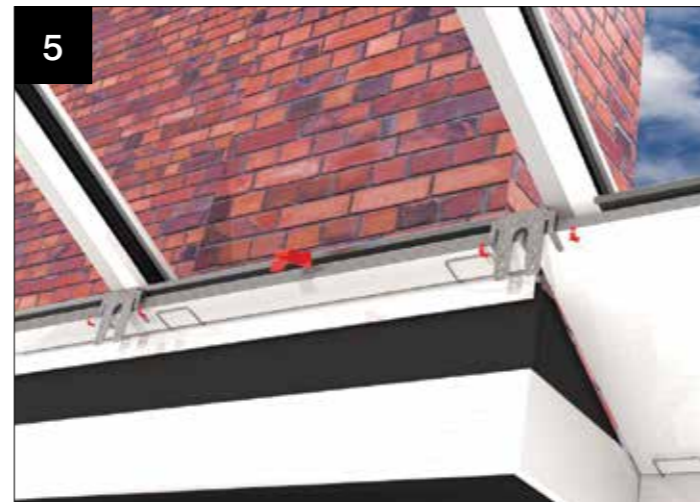

5 Fit the polycarbonate modesty panels and bend over bracket legs to secure.

INSTALLATION - INTEGRAL BOXGUTTER



7 Cross section shown for reference.



6 Fit back horizontal frame using CHA008 (bag of 25) as per standard installation.



7 Screw split horizontal frames together using CHAA006 (bag of 25).



8 Fix the vertical frames in place using CHAA006 (bag of 25) as per standard installation.

CHAMBERED BOX GUTTER

Clip the small PVCu profile on to the top barb of the aluminium box gutter and then commence installation of internal insulated pelmet. When on fascia, insert self adhesive packer as shown @ 500mm centres.

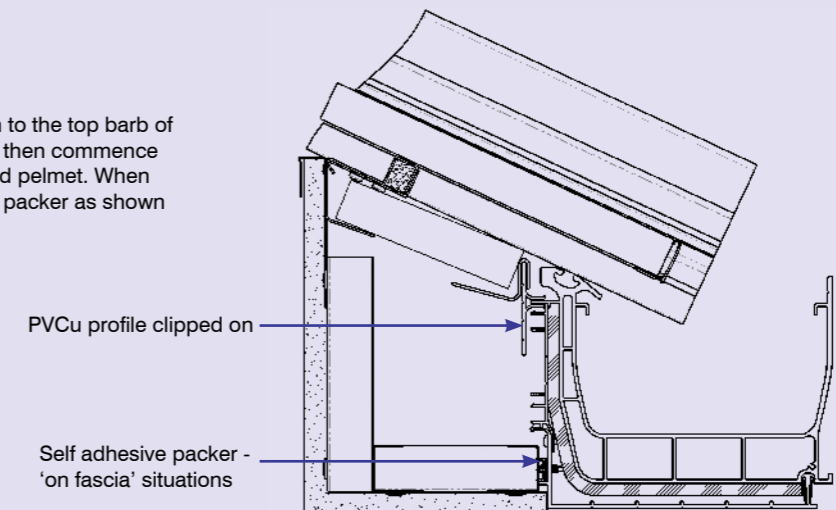

TYPICAL CROSS SECTIONS

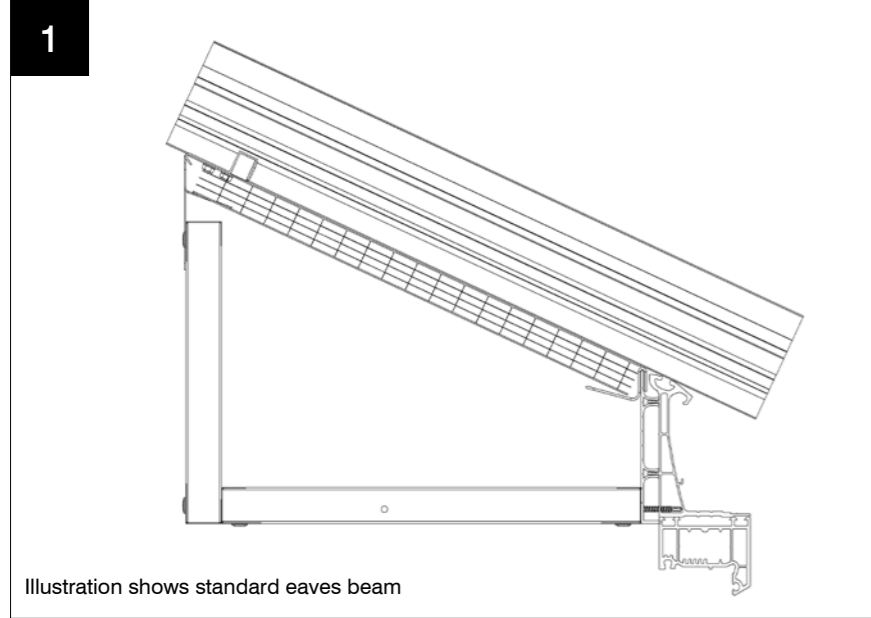

Ladder framework terminates on Fascia - standard eaves

Here we have the ladder steelwork terminating on the PFTB plank fascia (using standard eaves beam).

This detail is used when there are window frames around the complete perimeter and where there are no box gutters included in the design.

This design is also used if the ladder is retro fitted to an existing Ultraframe roof.

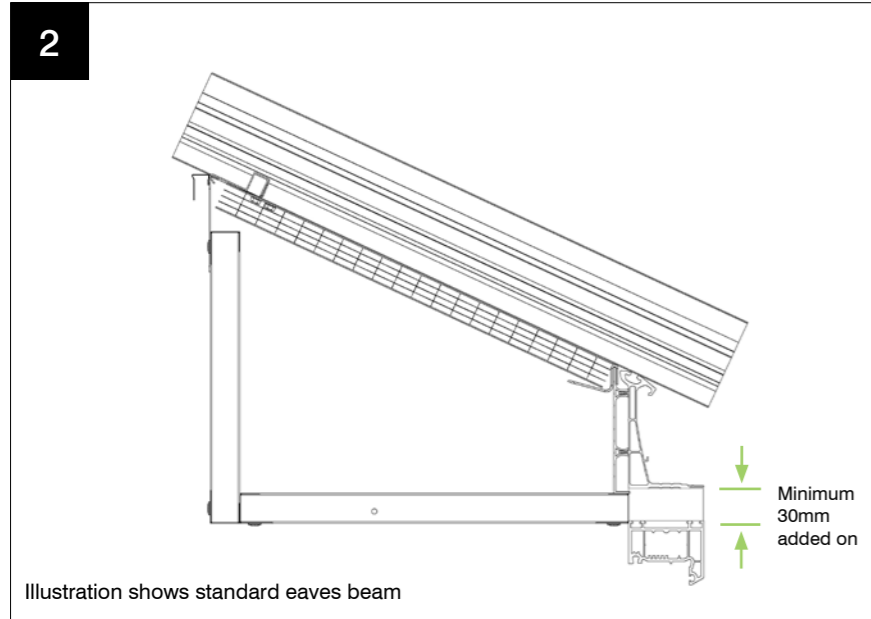

Ladder framework terminates below Fascia - standard eaves

This detail is used when there is a box gutter included in the design. The steelwork ladder terminates underneath the PFTB plank fascia.

Please note the following;

- window frames all round, a frame add-on of at least 30mm must be used.

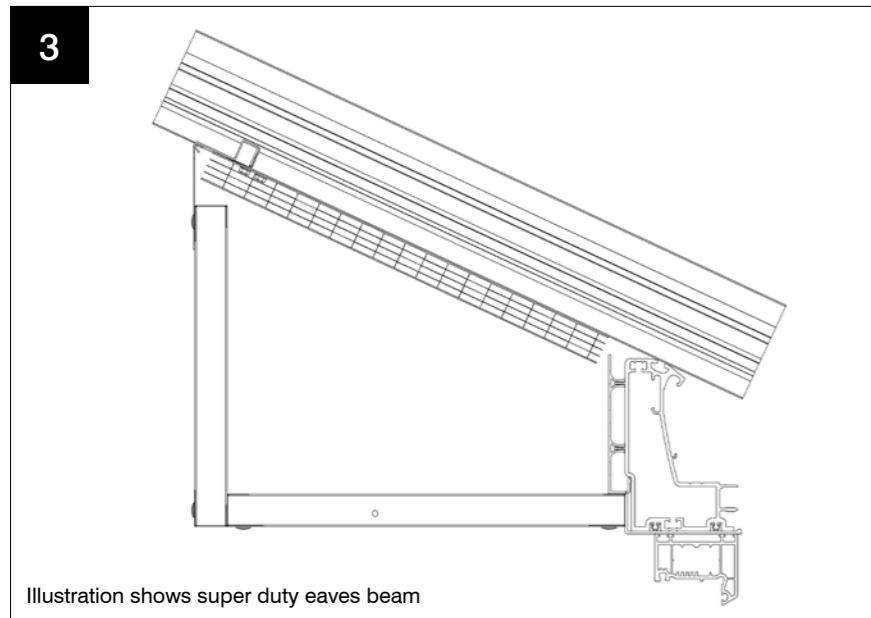

Ladder framework terminates below fascia - super duty eaves

Here we see the roof sat onto window frames featuring the super duty eaves beam which is used over large door openings.

The ladder steelwork terminates under the PFTB plank fascia.

TYPICAL CROSS SECTIONS

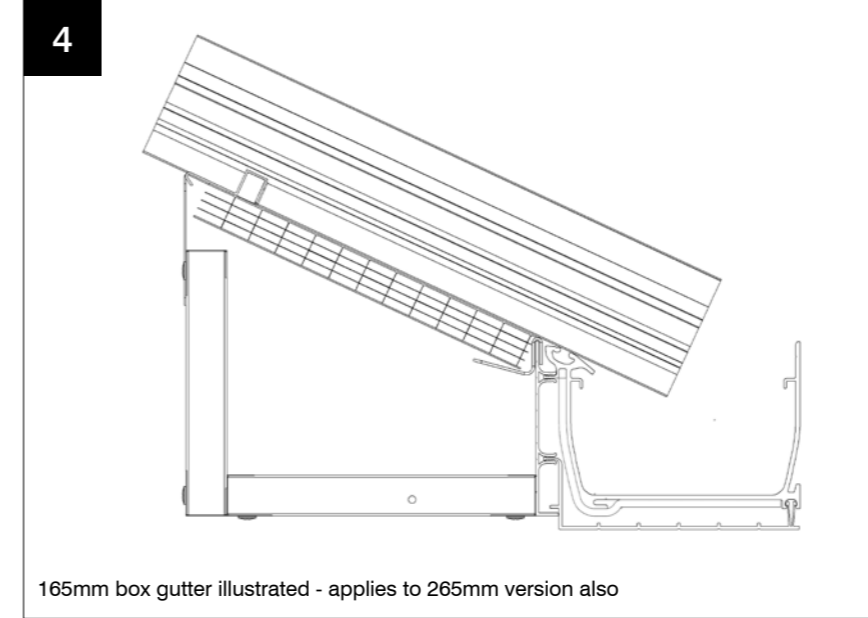

Box gutter - terminates on fascia

This detail is created when the ladder steelwork framework is retrospectively fitted to an already built conservatory.

Horizontal ladder framework terminates onto the box gutter cladding.

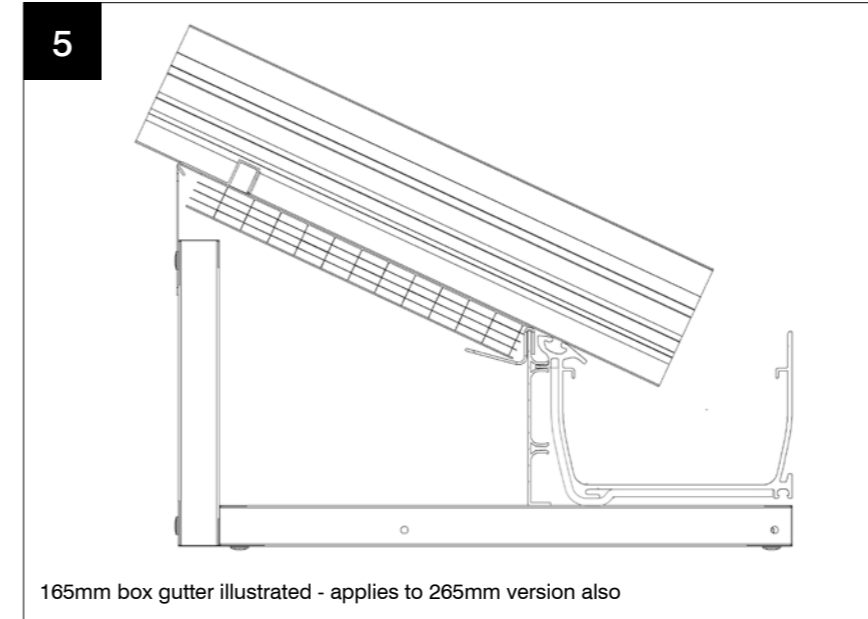

Box gutter - terminates below fascia

When starting a new installation that features a box gutter, this is the way the ladder framework is finished at the box gutter.

To ensure this detail is executed accurately, it is necessary to undertake the following;

- window frames all round, a frame add-on of at least 30mm must be used.

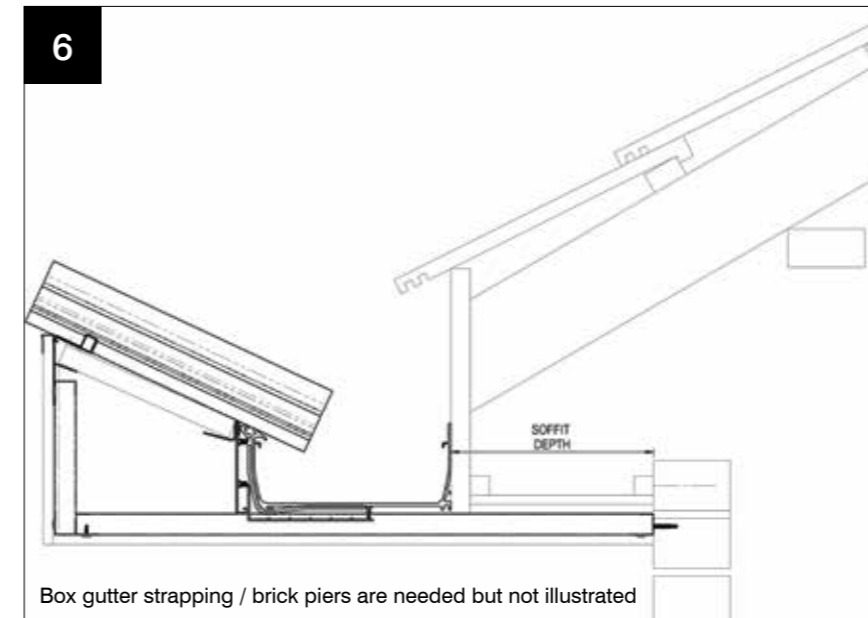

Box gutter - terminates onto bungalow fascia

To achieve this detail a 30mm add on is required and this allows the horizontal ladder to sail through to the host wall.

Please supply soffit depth when ordering.

TYPICAL CROSS SECTIONS

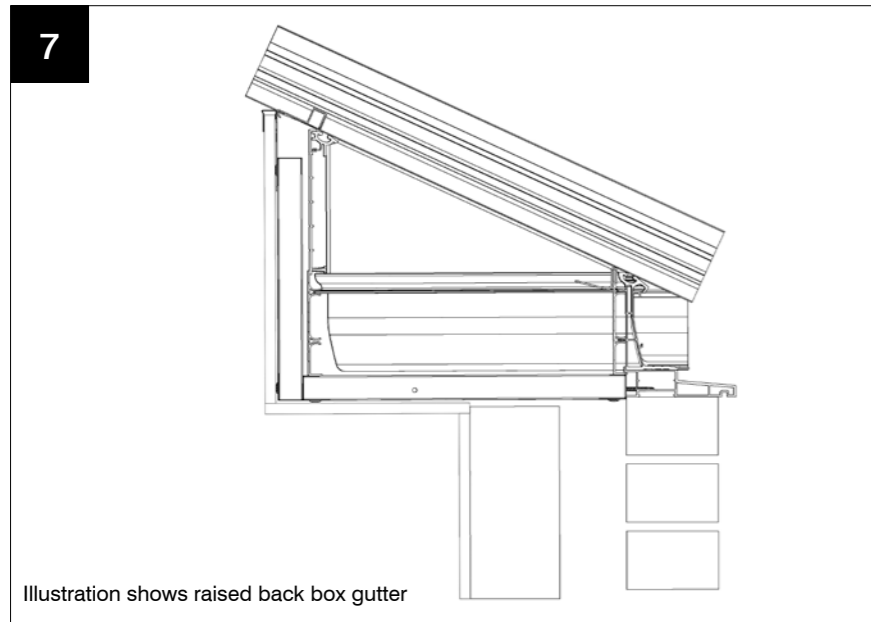
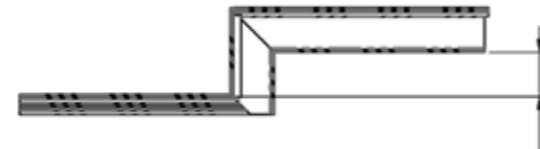

Illustration shows raised back box gutter

Box gutter - raised back

When the conservatory design features a raised back box gutter, this is the detail.

Please note the rule about 30mm add-on/cill applies.



Plan View: Raised back box gutter.

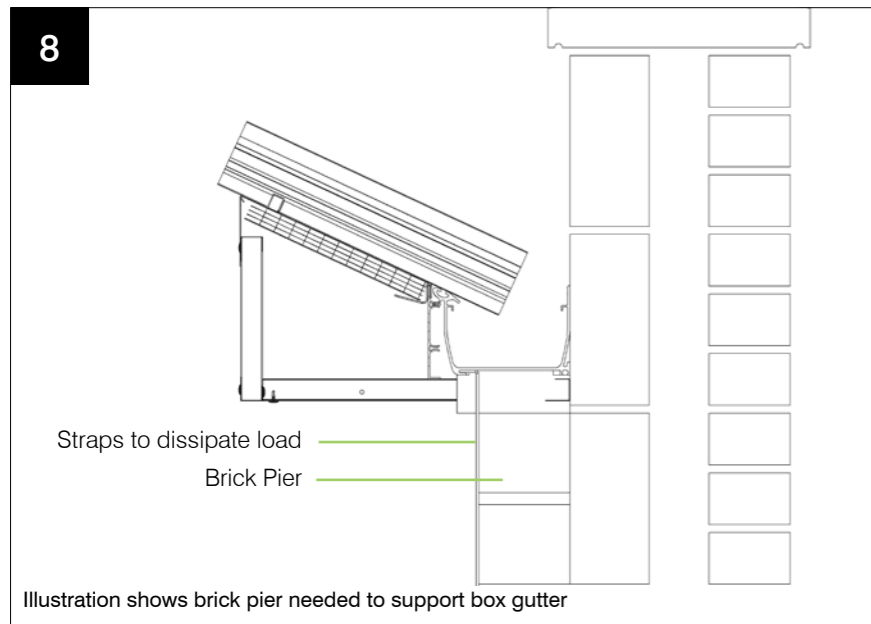

Illustration shows brick pier needed to support box gutter

Box gutter - masonry parapet wall

In this situation, a brick pier internally is necessary to support the box gutter. 30mm add on / cill necessary also to allow below fascia termination.



CHA165 or CHA265
Gallows Packer 165mm or
265mm

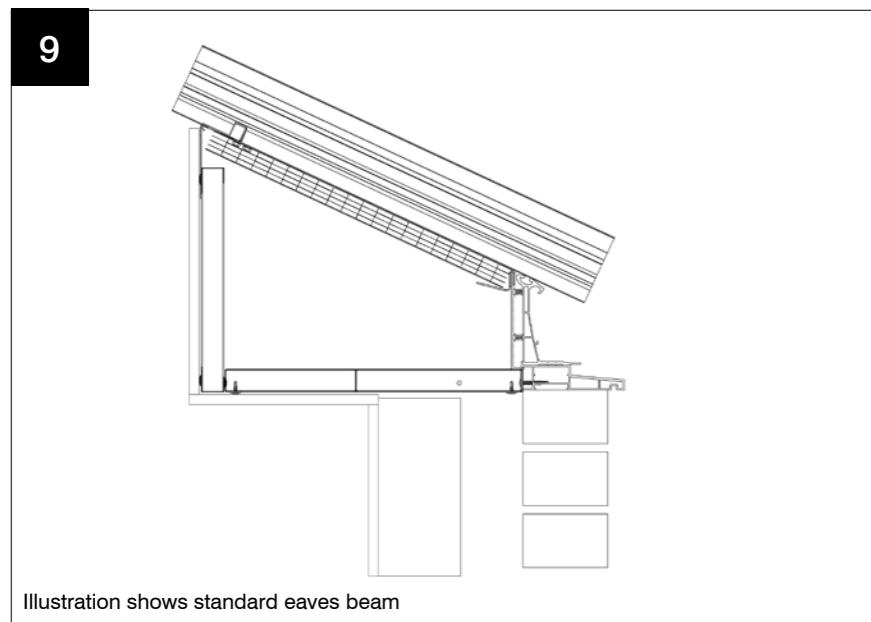

Illustration shows standard eaves beam

Standard eaves on cill

A minimum 30mm cill is needed to create this detail.

Horizontal ladder terminates below fascia. Internal block work MUST allow horizontal framework to fly through without interference.

TYPICAL CROSS SECTIONS

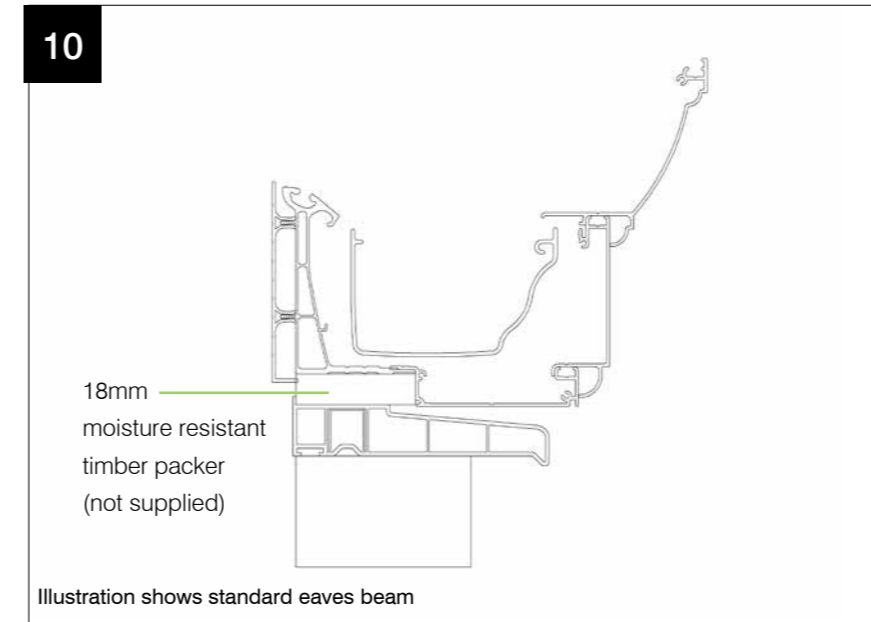

Illustration shows standard eaves beam

Standard eaves beam on cill with Cornice

When Cornice is used with a cill an 18mm timber packer is inserted.

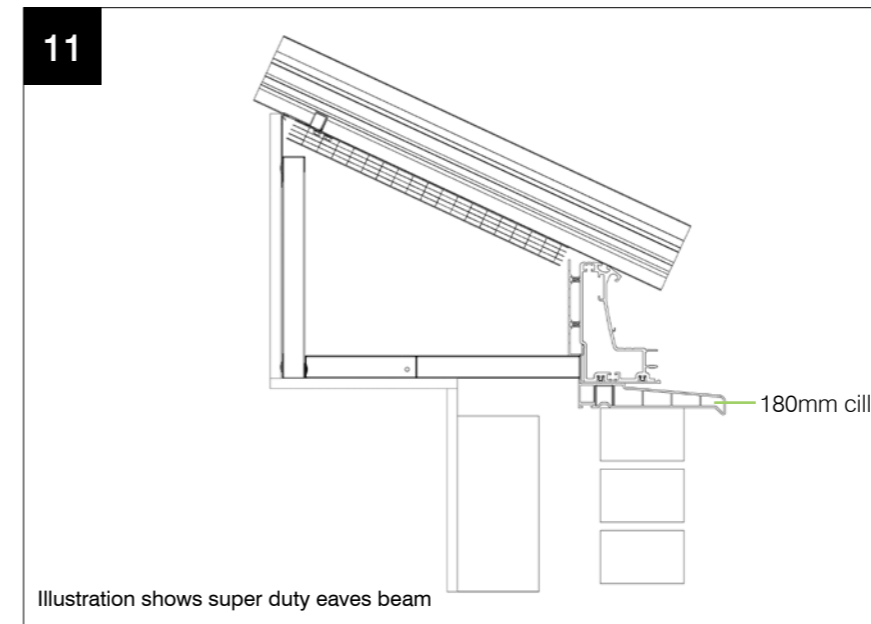

Illustration shows super duty eaves beam

Super Duty eaves on cill

When building the roof onto masonry, recommended good practice detail is to use a cill.

As the super duty eaves beam sits 'inboard' a further 25mm, we suggest using a 180mm cill.

As drawn, the ladder steelwork terminates below the PFTB plank fascia.

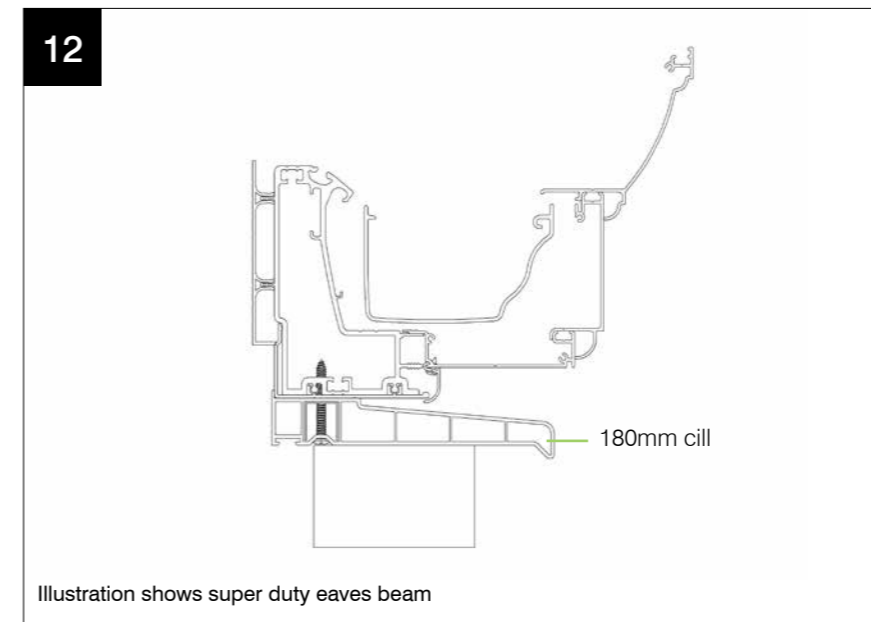
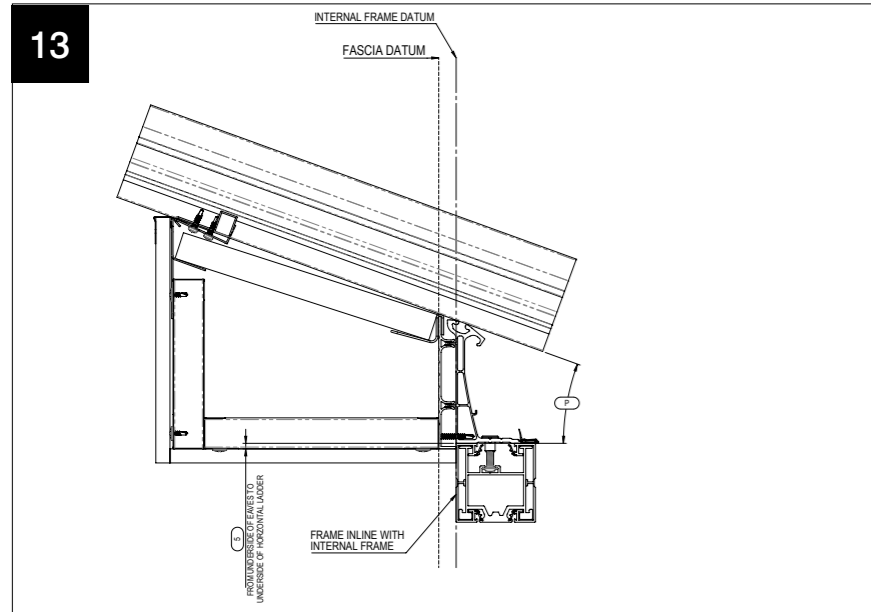

Illustration shows super duty eaves beam

Super Duty eaves beam on a 180mm cill with Cornice

In this situation, we recommend a slightly deeper cill than on standard eaves beam.

TYPICAL CROSS SECTIONS



Bi fold support on fascia

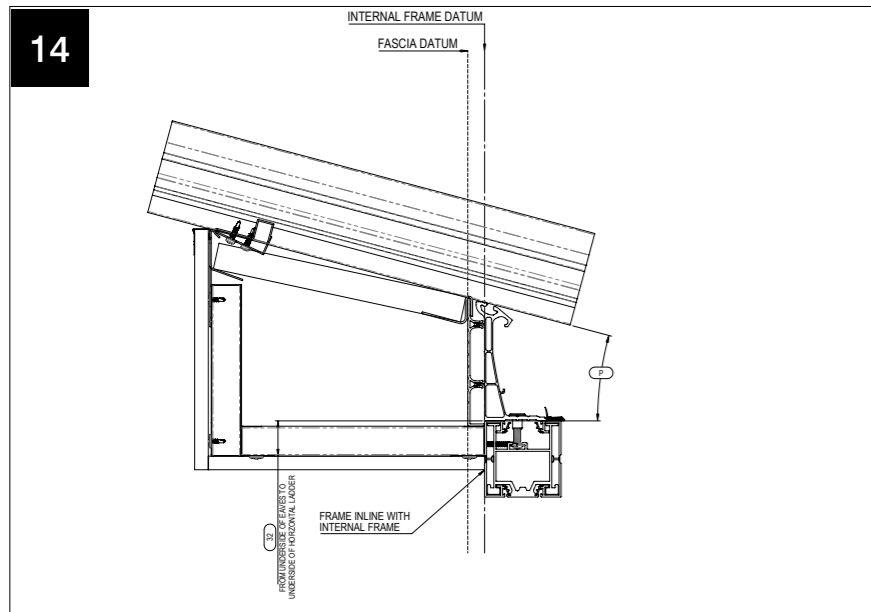

Bi fold support below fascia

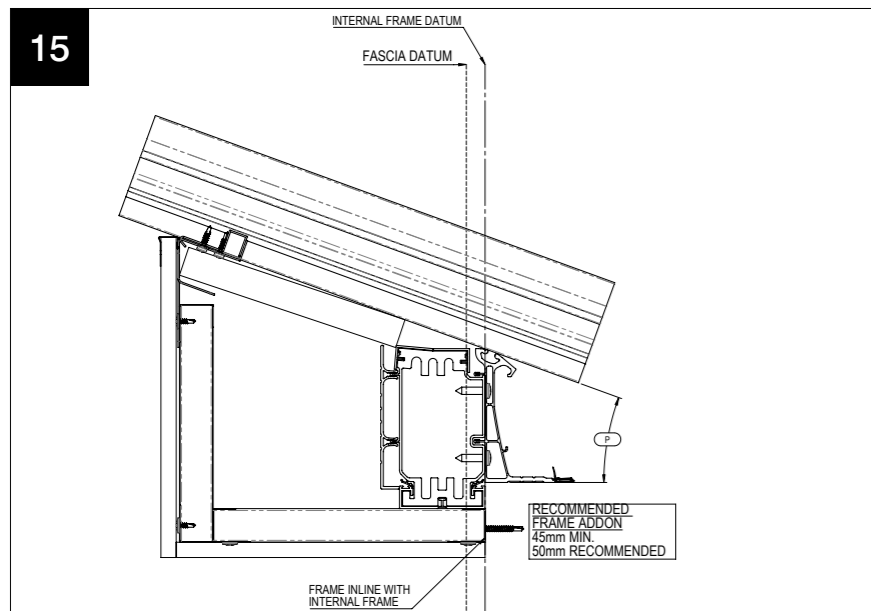

Eaves super bolster
Above 20° below fascia only

TYPICAL CROSS SECTIONS

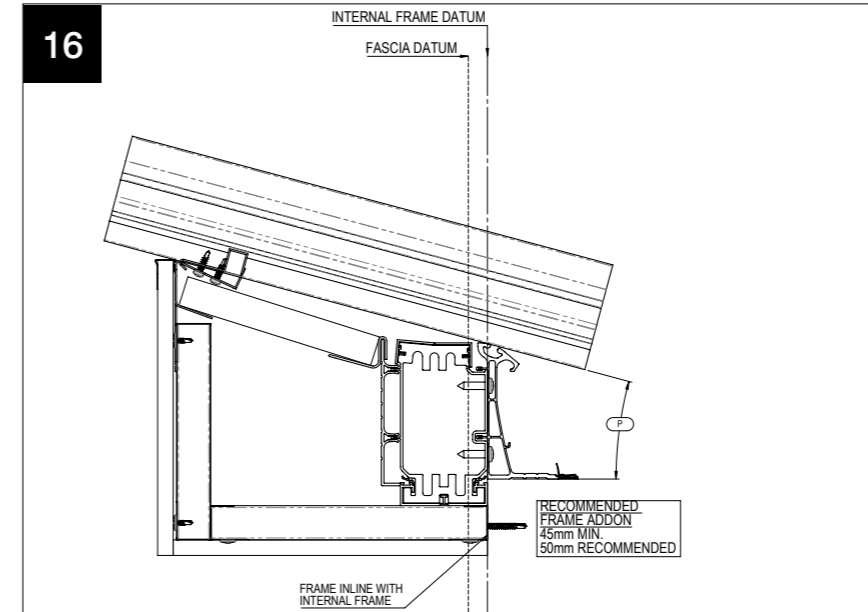

Eaves super bolster
Below 20° below fascia only

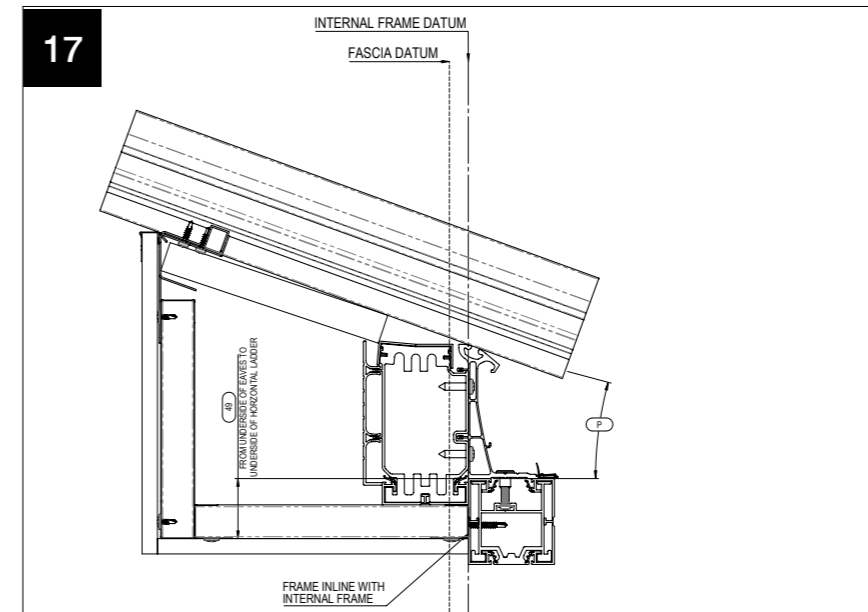

Above 20° combination support
below fascia only

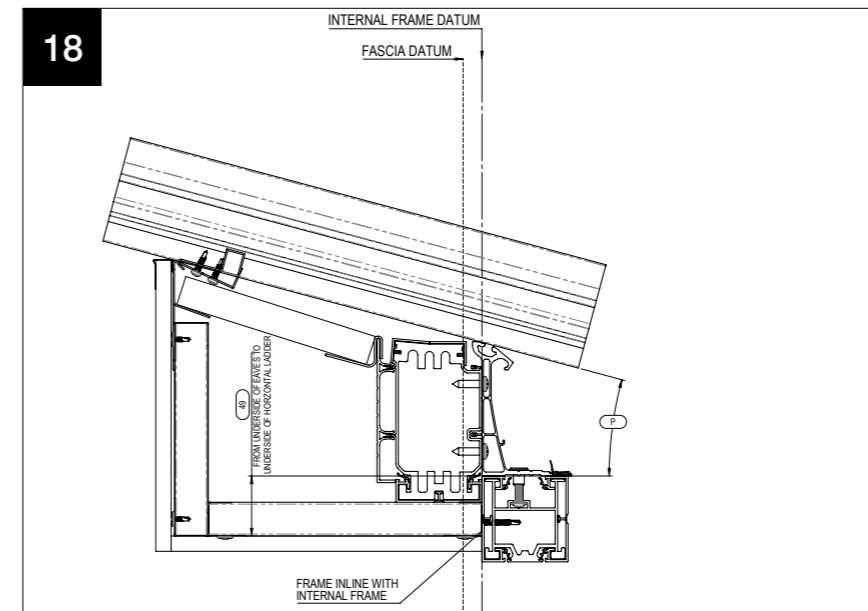

Below 20° combination support
below fascia only

www.ultraframetrade.co.uk

Job No.: 2683 CHA020 V9 April 2021

It is Ultraframe's policy to continually seek to improve its products, processes and services, and we reserve the right to change specifications without prior notice. Ultraframe is a trading name of Ultraframe (UK) Limited.

Ultraframe[®]

