

ultraframe

Transforming light and space



Super duty eaves beam & aluminium folding/sliding doors

Technology Guide

Version 3 | June 2014



Consumers enjoy their conservatories because of the unique way they add light and space to a home. Equally important is that it brings the home and garden together, blurring the margin between inside and outside space.

The introduction of folding/sliding doors into the UK conservatory market is adding further benefits to those already enjoyed by homeowners with a conservatory. In place of the single leaf or double door set – with obvious width restrictions – consumers can now buy the much wider 'bi-fold' type doors that effectively open up virtually a whole side of a conservatory.

To enable the confident use of these sliding/folding doors, Ultraframe has introduced a new 'Super Duty' aluminium eaves beam which allows additional span widths before a goalpost arrangement 'kicks in'. If you would like the Super Duty aluminium eaves on your next conservatory, please complete the roof order form on page 10 (or speak to your fabricator/trade supplier).

If you require extra wide openings – beyond the span capabilities of the Super Duty eaves beam - Ultraframe can design, structurally prove, fabricate and powder coat a custom support arrangement that meets your exact needs. For further help with this option please call 0870 414 1002.



Non standard designs are possible - please ask



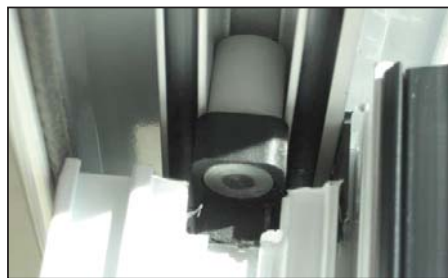
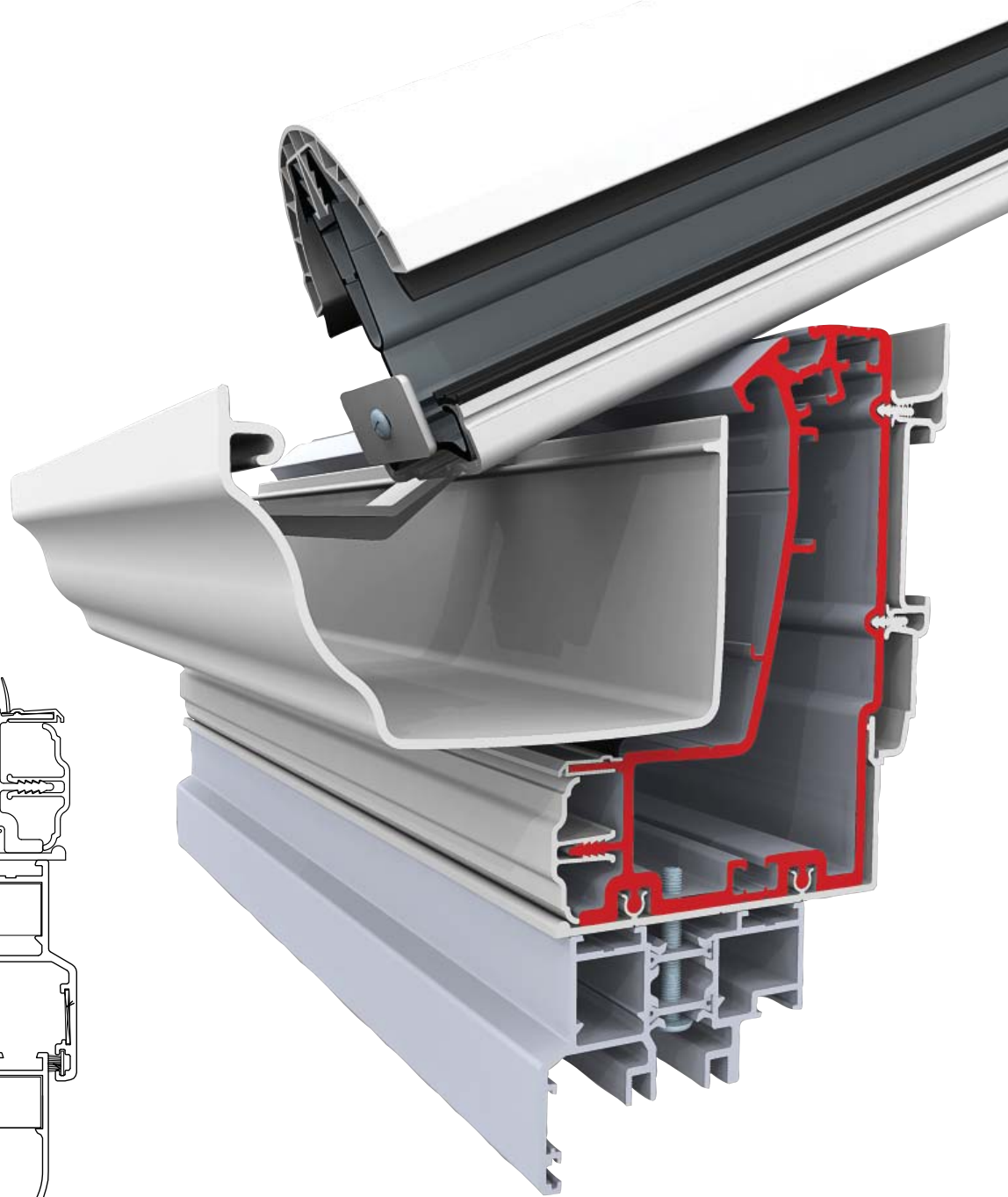
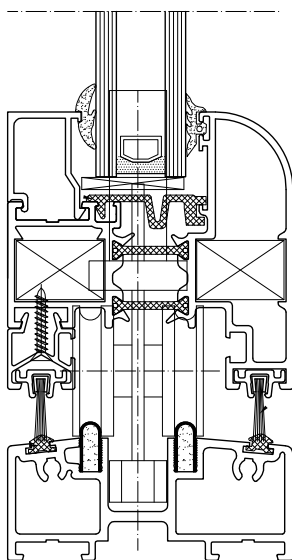
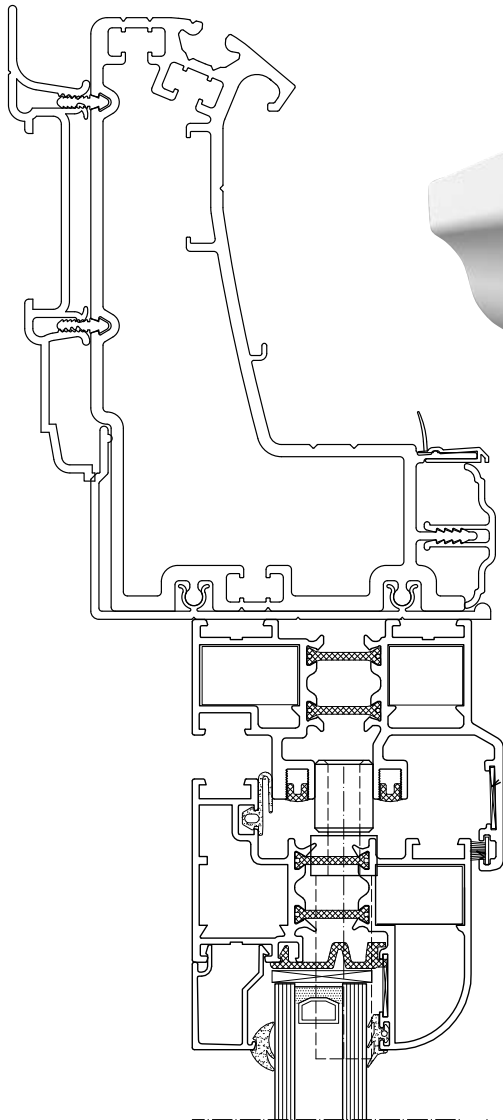

Typical detail - Actual detail may vary

Technical Specification

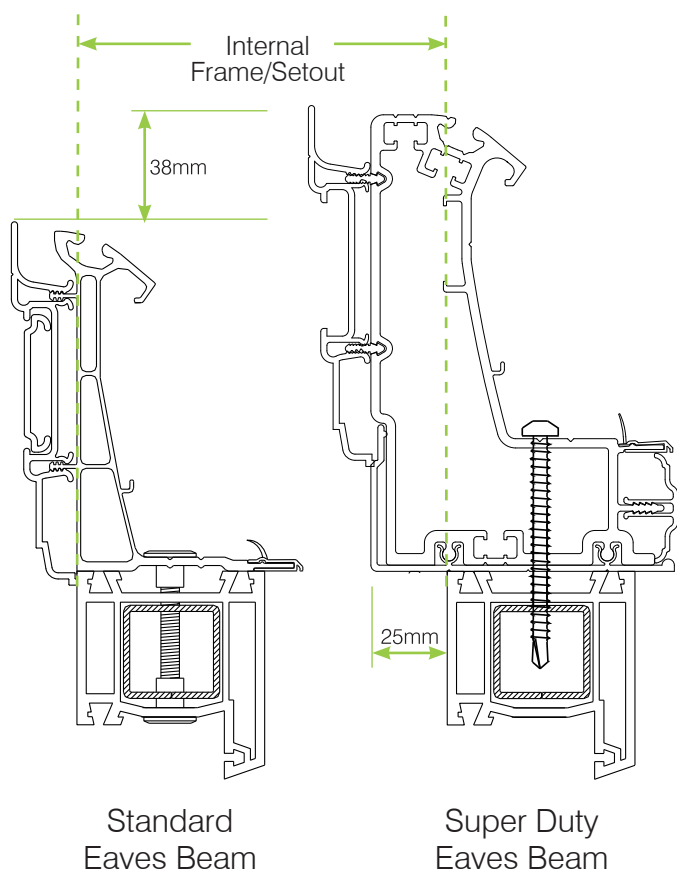

IMPORTANT NOTE FOR FITTERS

Super Duty Eaves Beam sits 38mm higher and eaves beam is further 25mm 'in board' of the frames

The Super Duty Eaves Beam allows confident specification of folding/sliding doors (or indeed any type of opening such as in-line sliders where additional spanning performance is needed).

- Structural 'beefier' aluminium profile that uses existing pvc components to clad and cap for optimum performance
- Sits 38mm taller than the standard eaves beam (remember this when calculating overall ridge heights). Be aware especially where height is critical, such as where windows above may foul or overhanging bungalow fascias.
- Needs to be specified all the way round the nominated conservatory and NOT simply on the facet into which the doors are to be fitted (this is critical when calculating the uplift price)
- Readily interfaces with box gutters and Gable Support Beam, to offer maximum integration and configurability
- Can be specified at pitches from 5-40° and in all existing Ultraframe Classic colours
- The span charts on the page opposite need to be studied carefully BEFORE conservatory selling and design starts.....the elevation into which the doors are to be fitted, the style of conservatory and the 'span onto' dimension all affect the maximum allowable width of opening when using the Super Duty Eaves Beam.
- If your conservatory design requires an opening width greater than that which can be offered with the Super Duty Eaves beam, then a portal/goalpost arrangement will be needed – please call 0870 414 1002 if you need a custom solution.

IMPORTANT NOTES FOR DESIGNERS/SPECIFIERS

1. We advise that a support post (not supplied) is used each side of the doors – this needs to attach to the Super Duty Eaves Beam and attach to the floor slab. It is the responsibility of the conservatory designer/specifier to provide full lateral and vertical support for the Super Duty Eaves Beam – loads are likely to be higher than conservatory retailers are used to.

2. The engineering performance of the Super Duty Eaves Beam is optimised for use with Ultraframe's aluminium bi-fold door offering.

All of the span charts published for the Super Duty Eaves beam are based on a maximum deflection of 7mm under full structural load, and the Ultraframe bi-fold doors can accommodate this degree of deflection without catching.

However, many alternative bi-fold doors are not designed for conservatory use, but to only sit inside lintel supported masonry openings where the deflections are minimal. Where these alternatives are used in conservatories, it is necessary to check with the system company/fabricator whether they can accommodate 7mm of deflection without catching.

Unfortunately, not considering this at the design stage can be very costly as it's not possible to easily rectify this once the doors are installed and catching.

The selection of what may appear to be bi-folds with an eye catching price may cost you more in the long term as a steel beam will probably be required to reduce deflection – clearly this is costly. Ignoring the issue of deflection may result in a disgruntled consumer, expensive call backs and remedial action.

To order your Classic roof featuring the Super Duty Eaves Beam, please complete the order form on page 10 and fax back to 0800 013 1939

Structural Span Performance

1. Opening span performance

Doors into the front elevation of a Lean to or a side elevation of a Victorian/Georgian/Gable style conservatory

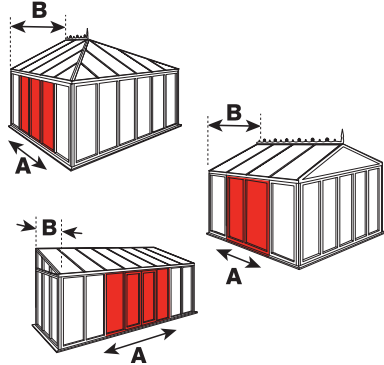

Super Duty Eaves Beam

Eaves Span Chart - Standard Load - Glass (4/../4) - Snow 0.6kN/m²

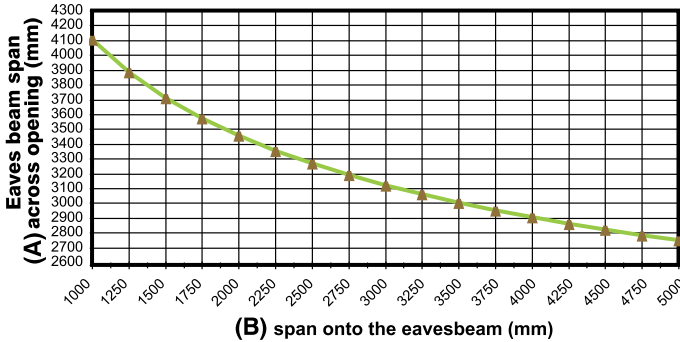

2. Opening span performance

Doors into the front elevation of a Georgian style conservatory with hip bars

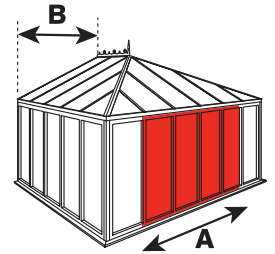

Super Duty Eaves Beam

Eaves Span Chart - Triangular Load - Glass (4/../4) - Snow 0.6kN/m²

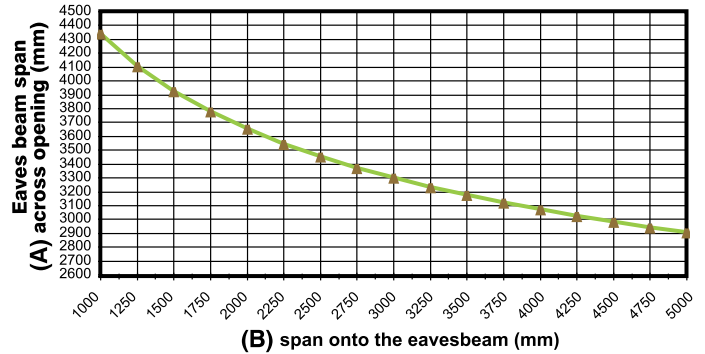

3. Opening span performance

Doors into the front elevation of a Gable style conservatory

This style uses the established Gable Support Beam for doors in the front and standard eaves beam on the sides. For doors in the sides, use Super Duty Eaves Beam on the sides and preferably, Gable Support Beam on the front - cost accordingly

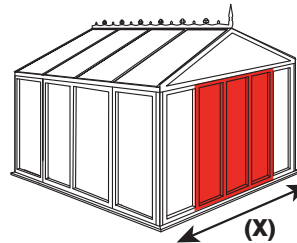
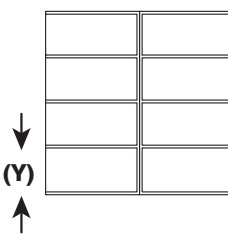

Example -
For a Gable conservatory with a width of 4000mm (X), a roof pitch of 25° and with 750mm distance to the first glazing bar (Y), the maximum opening span for the doors would be 2900mm.

Available unsupported span of Gable Eaves Beam (0.6kN/m² snowload and 4/../4mm glass units)

PITCH	FIRST BAR CENTRE (Y)	WIDTH OF GABLE (mm) (X)																
		1000	1250	1500	1750	2000	2250	2500	2750	3000	3250	3500	3750	4000	4250	4500	4750	5000
15°	1000									2900	2800	2750	2700	2650	2600	2550	2500	2450
15°	750										3100	3050	2950	2900	2850	2800	2750	2700
15°	600											3250	3200	3100	3050	3000	2950	2900
20°	1000									2900	2800	2750	2700	2650	2600	2550	2500	2450
20°	750										3100	3000	2950	2900	2850	2800	2750	2700
20°	600											3250	3200	3100	3050	3000	2950	2900
25°	1000									2900	2800	2750	2700	2600	2550	2500	2450	2400
25°	750										3100	3000	2950	2900	2800	2750	2700	2700
25°	600											3250	3150	3100	3050	3000	2950	2900
30°	1000									2850	2800	2750	2650	2600	2550	2500	2450	2400
35°	1000									2850	2800	2700	2650	2600	2550	2500	2450	2400
40°	1000									2850	2750	2700	2650	2550	2500	2500	2450	2400

All configurations in the shaded area have an opening span the full width of the conservatory

Assembly Details

Surveyors / conservatory designers / fitters should read these notes and drawings. Whilst some of the details are provided for roof fabrication businesses, ALL of these drawings need to be understood.

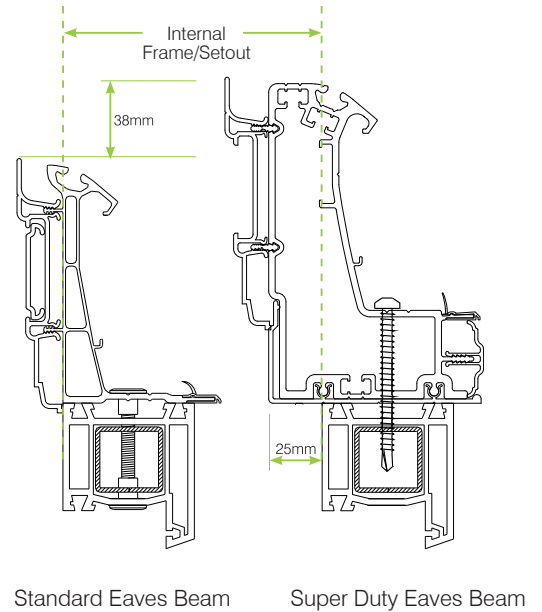

Inline jointing - Eaves Beam to Eaves Beam

- This detail is to be used when a run of eaves beam is greater than the maximum single stock length (6m)
- Spliced joints are to ensure accurate alignment of 2 extrusions
- When specifying spliced joints precautions must be taken to ensure that adequate support is provided beneath the joint
- Never place joints over doors
- Each spliced joint must be secured using 8 M6x16mm taptite screws (SFS001)
- Consult Ultraframe technical department for joint position advice

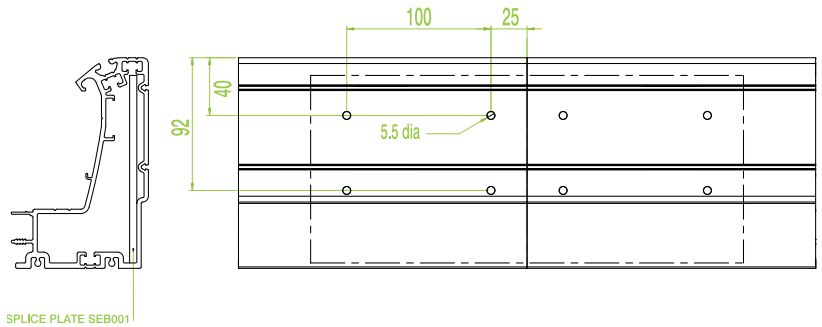

Inline jointing - Eaves Beam to Box Gutter

- To assist alignment with the box gutter, SES002 fitted to SEB---
- SEB004 fitted to SEB---
- Remember to ensure that SEB 003L/R is supplied
- Beware of the extra 38mm to the underside of the box gutter when ordering corner posts and other materials to fill the void below the box gutter
- Left hand joint shown with SEB 003L in-situ SEB to the left and box gutter to the right when viewed from inside the conservatory

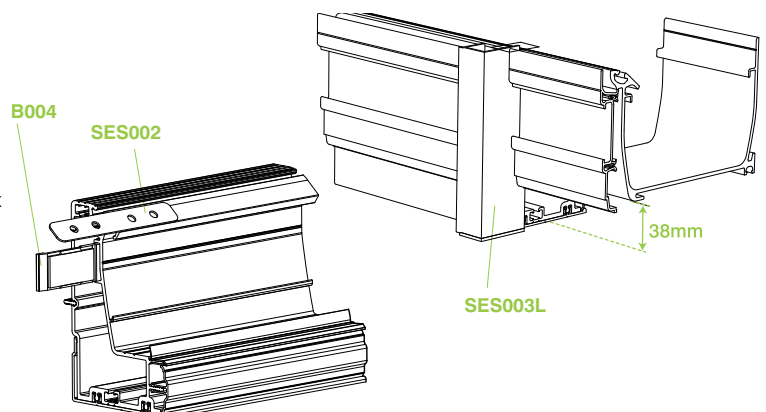

90° mitre - Eaves Beam to Box Gutter

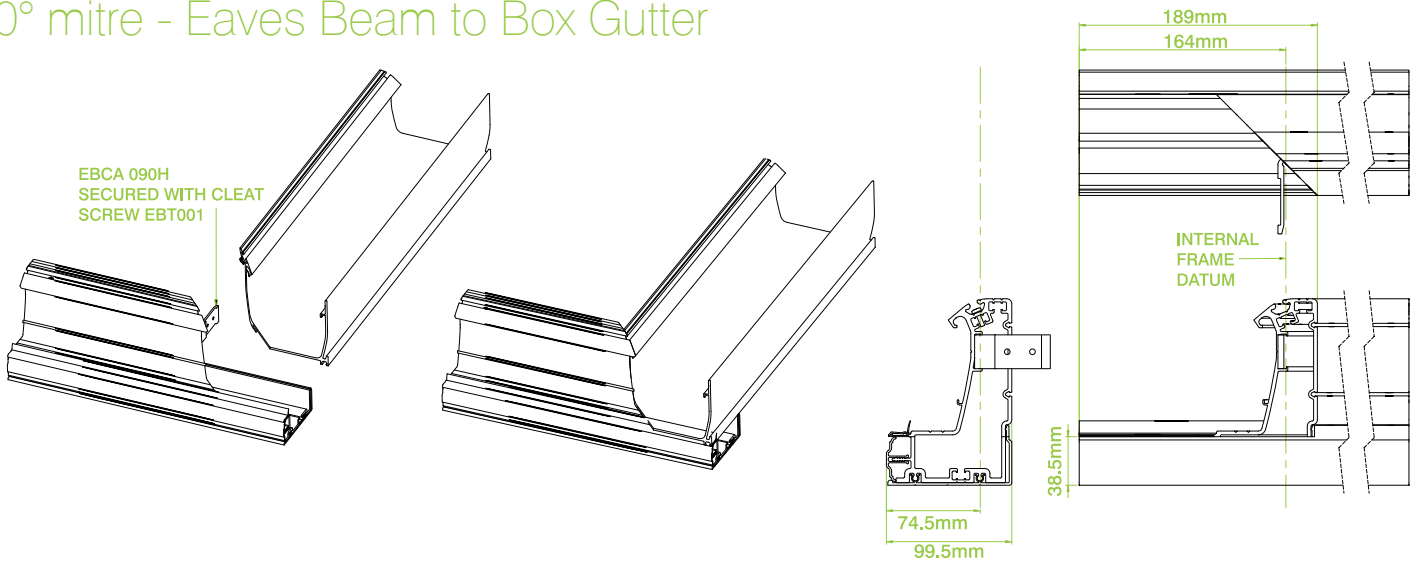

135° mitre - Eaves Beam to Box Gutter

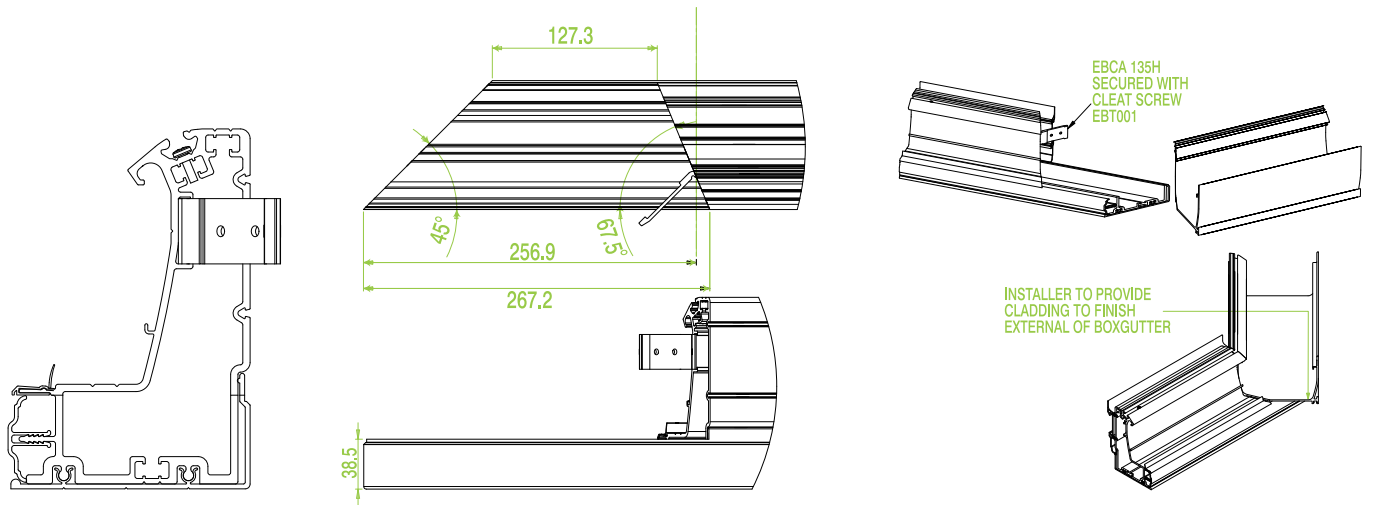

90° mitre - Eaves Beam to Gable Support Beam

- Surveyors/conservatory designers/fitters must be aware of the need to provide a 38mm infill to fill the gap beneath the Gable Support Beam and head of the frames

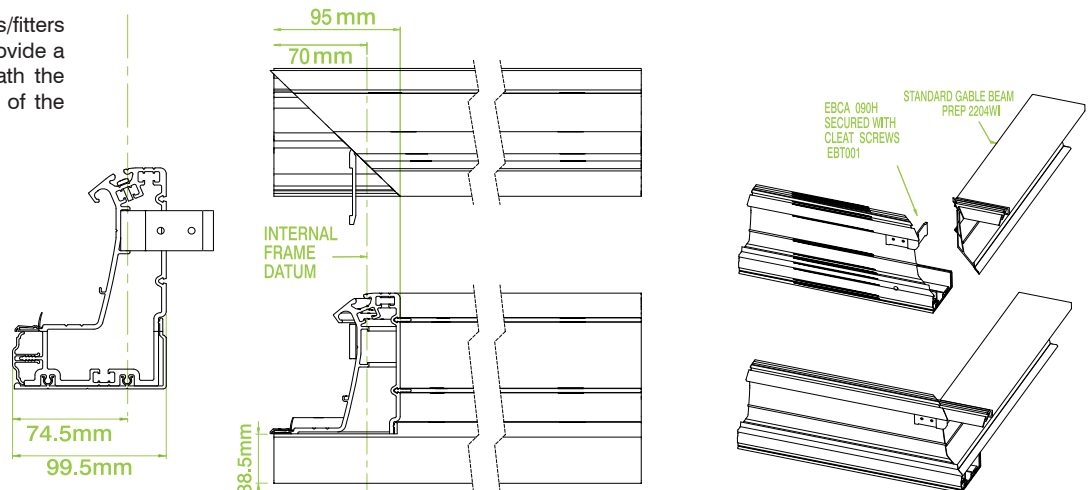

Technical Specification

- SMART Systems aluminium powder coated profiles
- 3-4-5-6 panel configurations available – right to left or left to right opening
- Traffic doors to left, right or central pairs
- Maximum width 6000mm opening, minimum opening 1800mm
- Maximum sash size is 1000mm, minimum 600mm
- Standard opening height is 2100mm, maximum height is 2500mm
- Colours – white is standard, other colours are available from the RAL colour chart.
- Doors are glazed with 28mm sealed units with a silver spacer bar – centre pane 'U' value of 1.2.

Options

- Aluminium cills – no cill is supplied as standard - choose from 150mm or 190mm
- Track – choose from an exposed weathering or sheltered elevation option
- Ventilation – this is in the form of a continuous slot vent in a 42mm add-on profile (profile can be left or right, top or bottom).
- Drainage – no drainage is provided, specify face drainage
- Door stacking – 'stack in' or 'stack out'

IMPORTANT NOTES FOR DESIGNERS/SPECIFIERS

1. We advise that a support post (not supplied) is used each side of the doors – this needs to attach to the Super Duty Eaves Beam and attach to the floor slab. It is the responsibility of the conservatory designer/specifier to provide full lateral and vertical support for the Super Duty Eaves Beam – loads are likely to be higher than conservatory retailers are used to.

2. When using Ultraframe's SMART system aluminium doors in conservatories, we strongly advise that this is in combination with the Classic roof system Super Duty Eaves Beam .

All of the span charts published for the Super Duty Eaves beam are based on a maximum deflection of 7mm under full structural load, and the Ultraframe bi-fold doors can accommodate this degree of deflection without catching.

However, many alternative bi-fold doors are not designed for conservatory use, but to only sit inside lintel supported masonry openings where the deflections are minimal. Many of these alternatives cannot accommodate 7mm of deflection without catching.

The selection of what may appear to be bi-folds with an eye catching price may cost you more in the long term as a steel beam will probably be required to reduce deflection – clearly this is costly. Ignoring the issue of deflection may result in a disgruntled consumer, expensive call backs and remedial action.

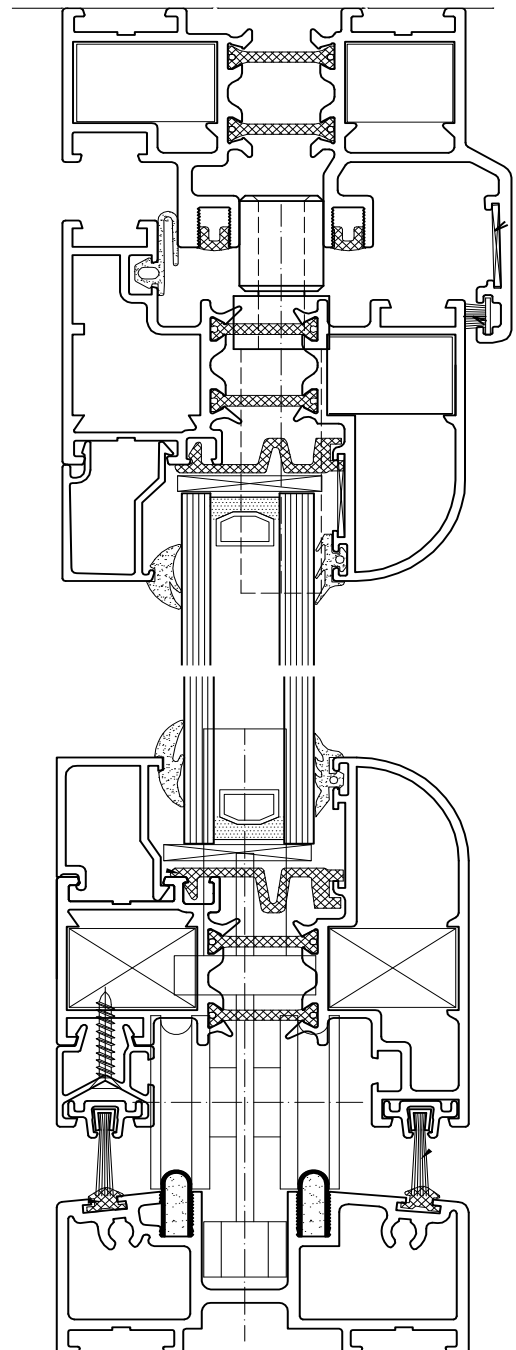



Loggia Prestige



Loggia Premium



Loggia Ultimate

QUANTAL

www.quantal.co.uk

ultraframe
Transforming light and space

www.ultraframe.co.uk