

Ultrarroof Valley Installation

The complete guide to installing Valley onto an Ultrarroof.
Used in conjunction with main installation guide.

PLEASE READ BEFORE FITTING

TOOLS REQUIRED



Clamps



2.5m straight edge



8mm Hex head socket



10 and 17mm spanner



Tape measure



Staple gun



6mm drillbit



Pozi PZ2
Phillips PH2
Phillips PH3

Driver bits



Drill/impact screwdriver



Plumb bob and string line



Scaffolding to exterior or 2 towers with Youngman boards



Long (1,500mm) and short spirit levels



Heat gun



Anglefinder



Gasket Shears/ Snips



Acro prop



Cat / roof ladder



Deadblow Hammer or White Rubber Mallet

NOT SUPPLIED:

Several items are not supplied by Ultraframe as they are easier and cheaper to source locally.

These are:-

- Velux roof windows and EDL flashing kits (the roof arrives prepared for Velux. **Note: 15 degree minimum pitch.**)
- Anchor or Masonry fixing bolts to host wall
- 12.5 foiled backed plaster board and skimming beads
- LED (fire resistant) lighting
- Internal 20mm x 50mm, 25mm x 50mm timber plastering battens
- Timber support props (75mm x 50mm) beam support
- Structural support (available from Ultraframe)
- Frame to boxbeam fixings
- Mineral wool/ expanding form (for filling small apertures)

HEALTH & SAFETY

Site safety is paramount. The Construction (Design & Management) Regulations 2015 apply to the whole construction process, on all construction projects from concept through to completion. Compliance is required to ensure construction projects are carried out in a way that secures health and safety. The installation company shall be responsible for the safety of all of the fitting team, the customer and members of the public.

The Surveyor should have carried out a written risk assessment to reduce risk on site and this should have been discussed with you (the installer) prior to starting.

Please use safe working platforms/ scaffolding all round and ladders that comply with BS EN 131. Always use equipment in line with manufacturers recommendations. Personal Protective Equipment – such as goggles, mask and ear defenders – should be used when, for example, grinding out for the flashing. **Downlighters must be LED IC (Insulation Contact) fire rated.**

GENERAL VALLEY INSTALLATION

Used in conjunction with main installation guide.

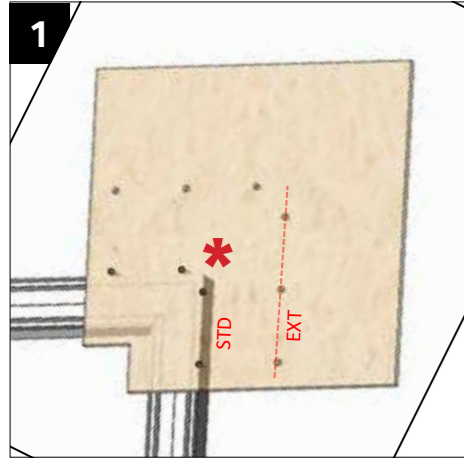

Apply low modulus neutral clear silicone to head of frames as per main guide. Position valley beam support shelf in desired soffit position and secure through frames using NRBA012 counter sunk self drill screws.

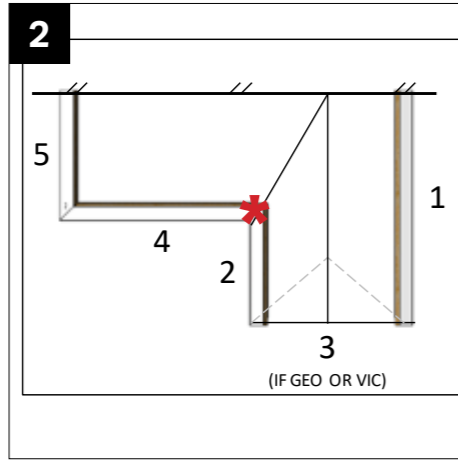

Assemble beams in sequence shown. Note: Example shows gable front; if Georgian or Victorian fronted, assemble front facet beams at stage 3. See main guide.

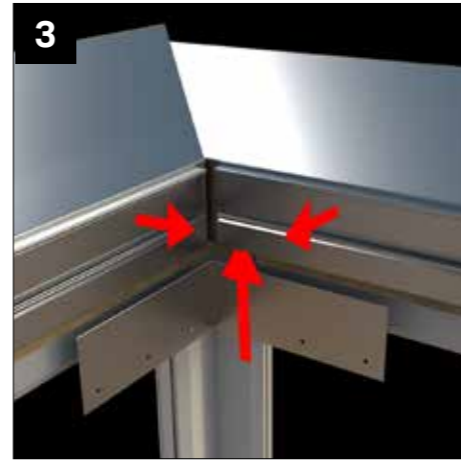

Fit corner cleat external to beam at valley eaves – ease out gutter support channel, removing any screws if necessary, and slide cleat behind. Line up lower edge of cleat with lower edge of steel and fix using NRTS100, 12 per cleat.

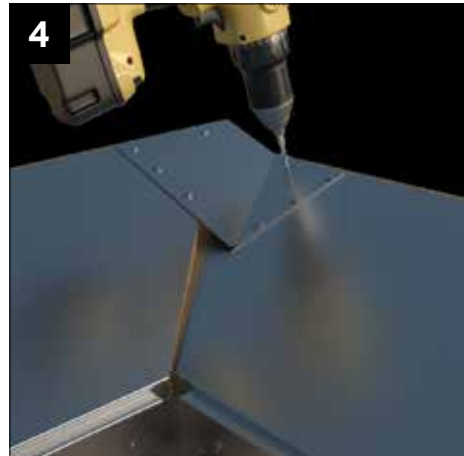

Position box beam valley cleat across the beams and secure using NRTS100 screws in positions shown. This should align with the OSB and the fold should point towards the outside corner of the beams as shown.



Position valley support bracket on beam. Line the bracket up with top of the panel shelf and end of the opposing beam as shown. Fix valley support bracket using NRTS100 screws.

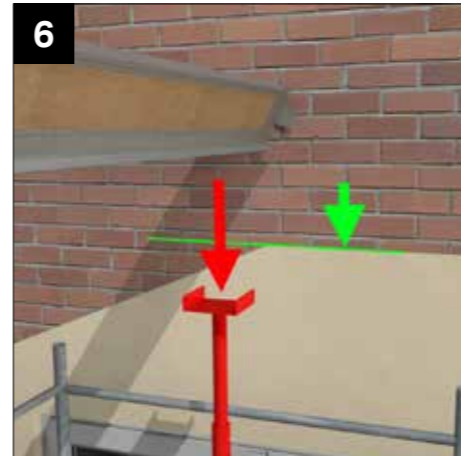

Sit the full ridge onto the support stand. Set the stand height to suit the dimension given on the critical dimension sheet.

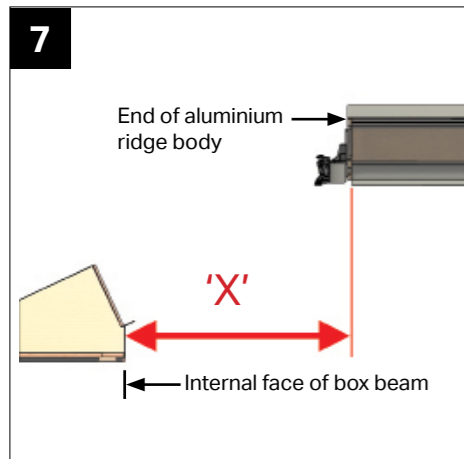

To set the ridge check critical dimension job sheet for dimension 'x'.

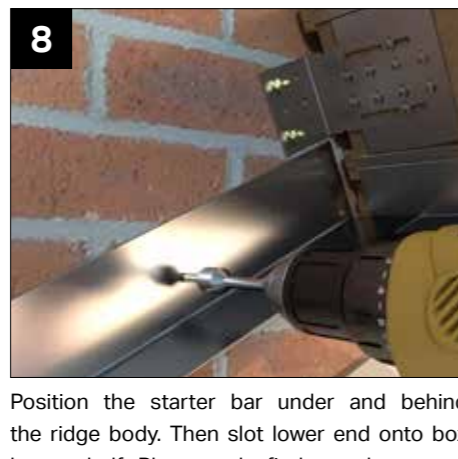

Position the starter bar under and behind the ridge body. Then slot lower end onto box beam shelf. Place angle finder under starter bar to check the pitch. Fix aluminium starter bar extrusions to the host wall (pack off where needed) within 200mm of ridge and box beam plus at least one more equidistant between the two. Use resin anchors suitable for substrate (NOT PROVIDED).

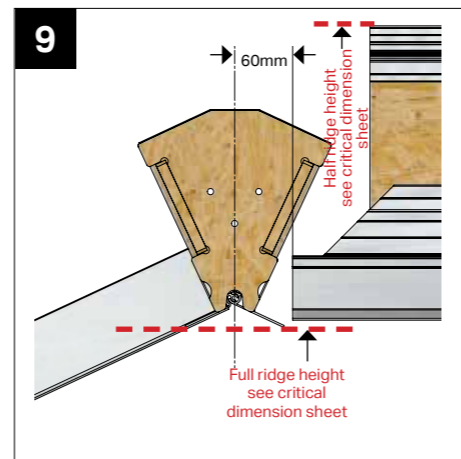

Next, install the half ridge body. Check the Critical Dimensions sheet for the correct height. The half ridge is set 60mm away from centre line of full ridge.

GENERAL VALLEY INSTALLATION

Used in conjunction with main installation guide.

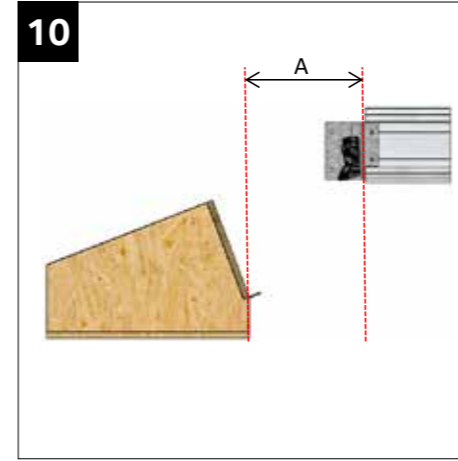

An additional dimension "A" will be supplied if the return features a hip (Shown above) in the case of a gable the half ridge should be aligned with the internal frame line, or 10mm offset if terminating at a host wall.



If the design features a hip on the half ridge then this should be fitted now. The hip bracket is pre-fitted to the half ridge but also requires fastening back to the wall using fixings suitable for the substrate.



The valley beam is pre-cut to fit into its position between the eaves and the converging ridges.

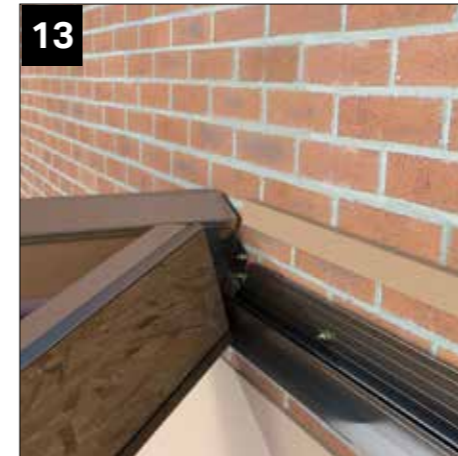

The valley beam sits at the top which interact with the ridges in the same way as those on the panels.

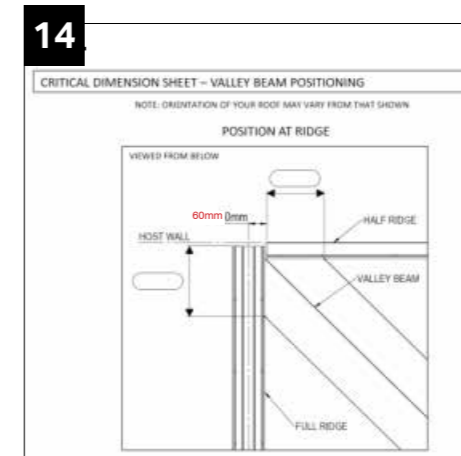

The documents supplied with the roof include a Setout Report. This should be used to mark out the ridges and eaves to aid correct positioning of the valley beam.

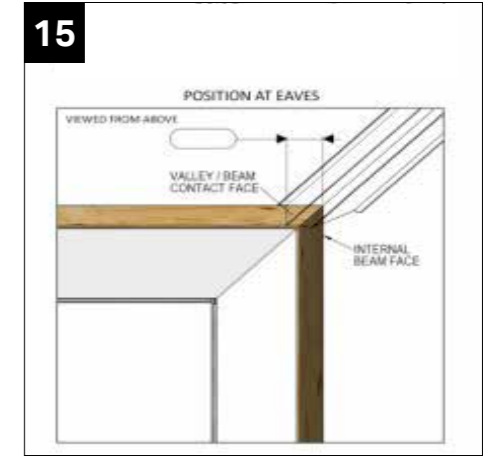

Lower the top of the valley into position. The centre line of the valley should strike through to the centre line of the full ridge. Set to dimensions given on critical dimension sheet. Secure using RRR025 hex head screws.



Lower the bottom end of the valley beam into position; resting on the panel shelf and valley support bracket as shown. Again, use Setout Report to check setout dimensions and secure using RRR025 hex head screws.

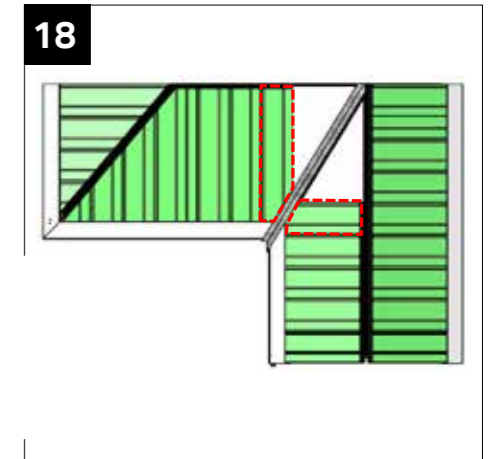

Insert panels in positions shown first. Panels on the valley rest on the lower steel shelf on the valley beam.

GENERAL VALLEY INSTALLATION

Used in conjunction with main installation guide.

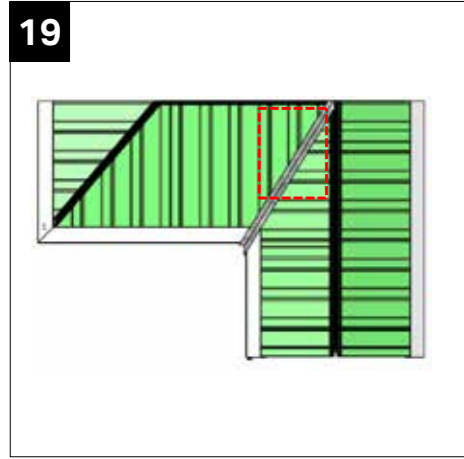

Insert the remainder of the roof panels. The panels can be then secured to the ridge, hips and eaves (see main guide). Next, fit OSB panels as per standard installation guide.

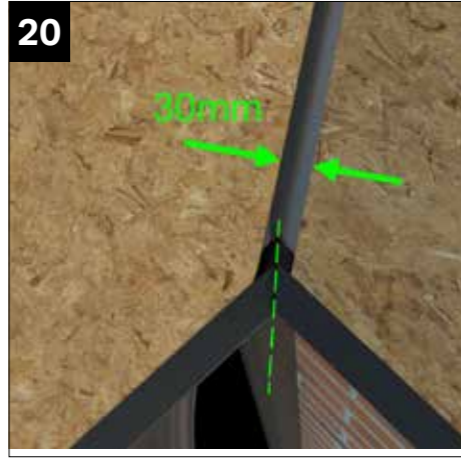

Tile starter supports are mitred. These mitres will need to be re-cut and re-positioned if there is a pitch difference over the valley. Ensure the lower edge of the tile starter support abuts external panel clips. See main guide image 52, page 25.

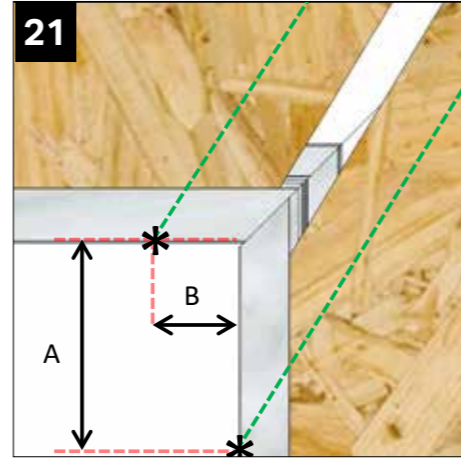

To ensure the steel valley plate is correctly positioned, dimensions "A" and "B" (plus similar at the ridge) are provided on the Critical Dimensions Sheet. These indicate where the edges of the plate should intersect the tile starter support.

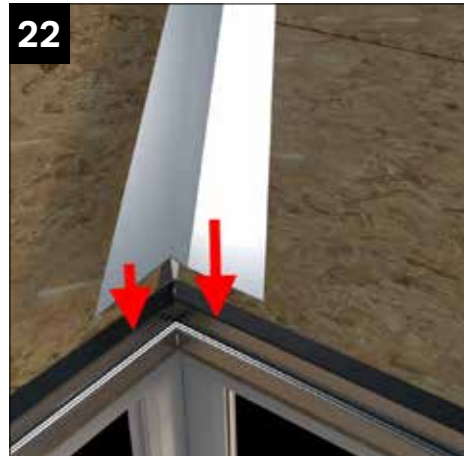

Position steel valley plate, with birds-mouth prep at eaves, and check position in relation to dimensions marked out in previous step. Accuracy at this stage is vital to aid with tile installation later on.

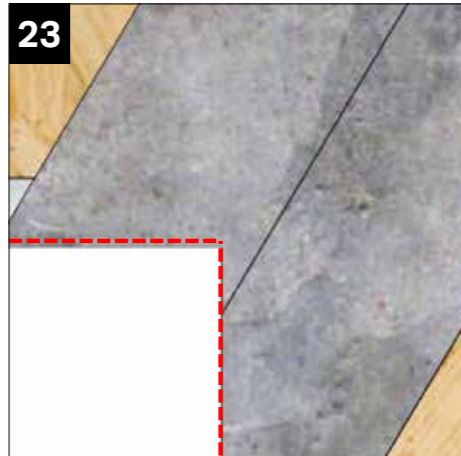

Birds-mouth prep at the eaves should align with outer edge of tile starter supports as shown.

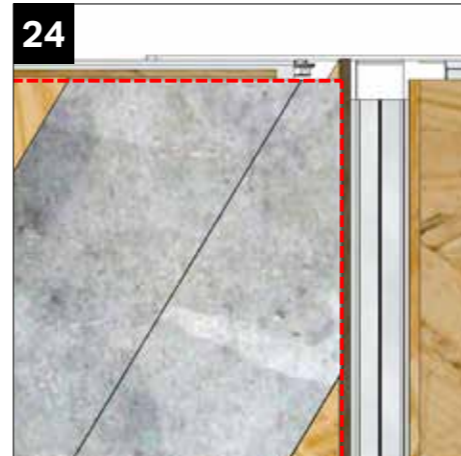

The upper (ridge end) prep should align with the OSB as shown. Dimensions are also provided in the Critical Dimensions Sheet to check proper alignment. Secure valley plate using NRTS100 screws at 300mm centres through predrilled holes.

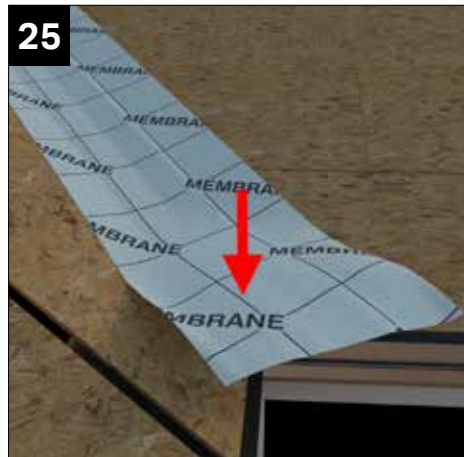

In addition to the standard installation of the breathable membrane (see standard guide); the valley should be lined with a full width strip of membrane as shown before continuing with the installation.

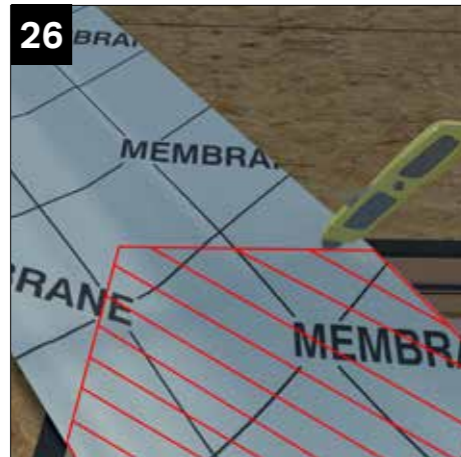

Trim the membrane in line with the outer edge of the tile starter support.



Continue applying membrane, lapping across the valley to ensure an effective installation.

GENERAL VALLEY INSTALLATION

Used in conjunction with main installation guide.



In practice, we have found it easiest and safest to install the membrane from top to bottom, under-lapping subsequent layers as you move down the roof.

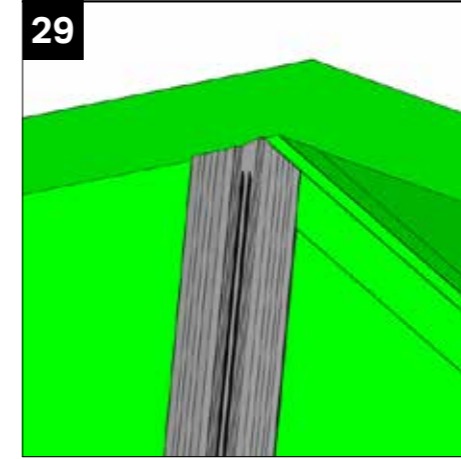

The Valley trough is supplied in 3 metre lengths. This should be installed over the breather membrane in the position shown before tiling.

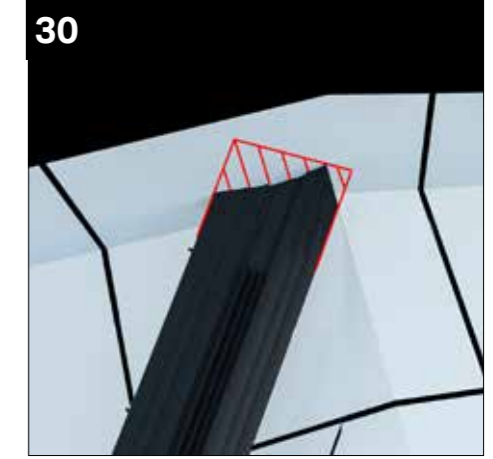

The Valley trough is the same width as the steel valley plate, this can be used as a setout aid. Feel for the edge of this plate through the membrane and mark a line to ensure correct positioning.

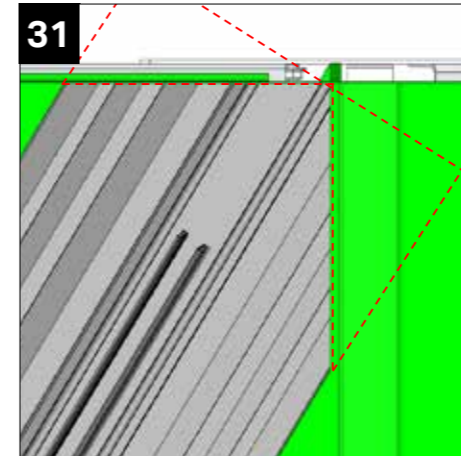

One end of the valley trough is pre-notched for overlapping/extenting – start at the top of the valley with the notch towards the wall as shown and trim as indicated. The notch will help when fitting ridge components later on.



If the valley is longer than 3 metres, underlap subsequent sections as shown to allow any water to flow freely from top to bottom.

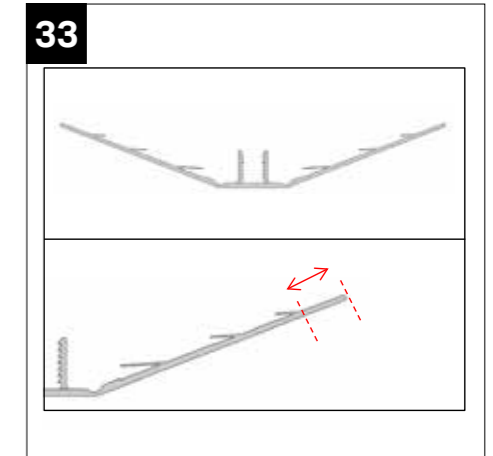

The valley trough should be secured using NRTS100 screws at 500mm centres along each side. It is important that any screws used only go through the valley trough in the region shown (outside of the smallest rubber seal)



Trim valley trough at the eaves in line with the outer edge of the tile starter support.

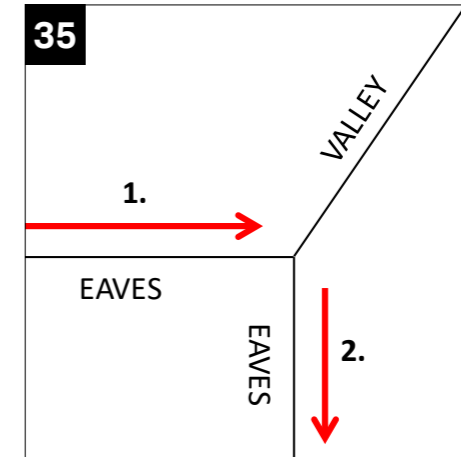

Tile roof as per main installation guide. Work anti-clockwise towards the valley from left to right (1.) then away from the valley from left to right (2.)

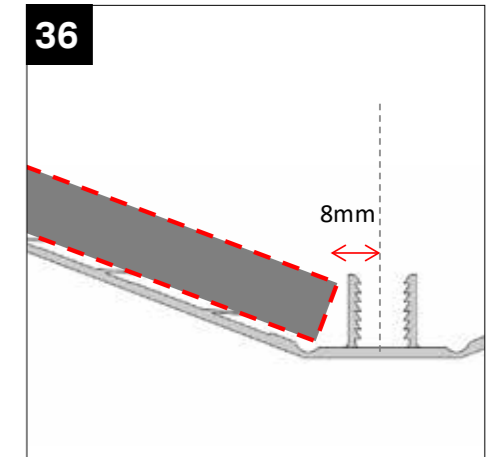

If cut and installed correctly, the tiles should finish at approximately 8mm from the centreline of the valley trough as shown.

GENERAL VALLEY INSTALLATION

Used in conjunction with main installation guide.

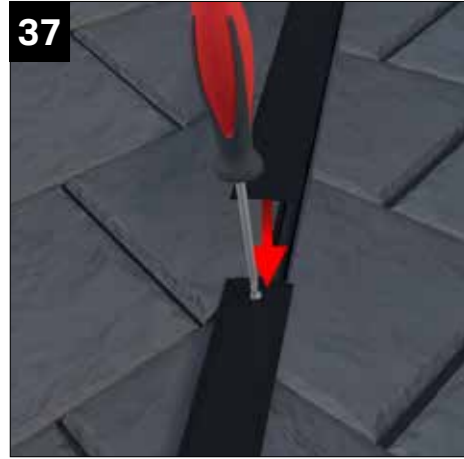

37 Once tiling on both sides of the valley is complete, install the valley caps to finish. These clip into the central slot of the valley trough.

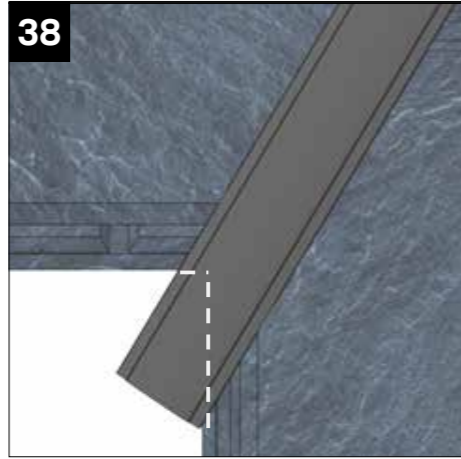

38 Position the first cap at the eaves and extend beyond the tiles to allow for trimming as shown.

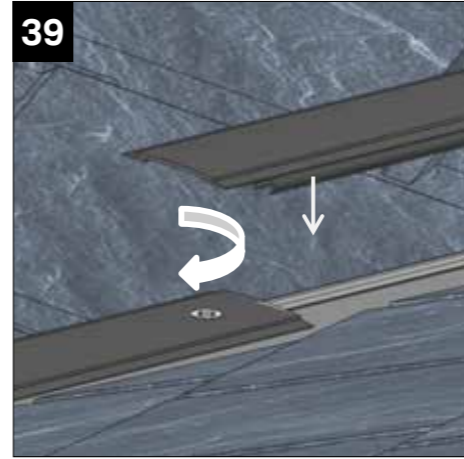

39 The supplied valley caps feature an integral screw at one end and a notch at the other. Work up the valley from eaves to ridge positioning the integral fixing screw towards the top. Tighten the screw to secure and cover the screws heads with each subsequent cap.

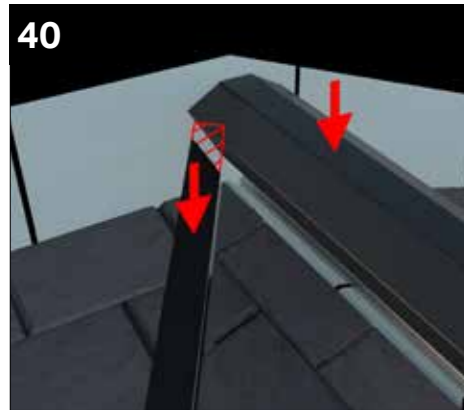

40 Fit ridge cap before fitting the last valley trough top cap. Centralise ridge cap over apex and position 10mm away from the host wall. Fix using 5.5mm x 90mm screws (NRRS005) at max. 750mm centres. **NOTE: It may be necessary to trim back the valley trough clip legs to allow the ridge cap to sit properly.**

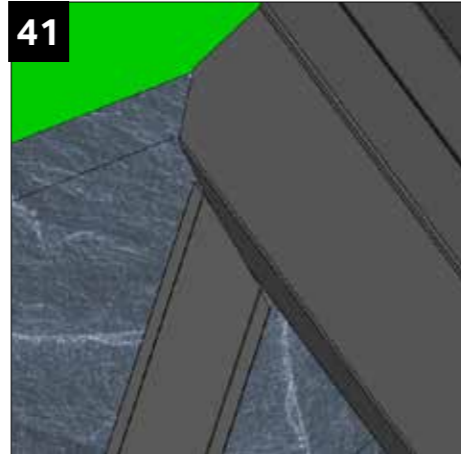

41 Install the last valley cap and scribe in line with the side of the ridge cap as illustrated.

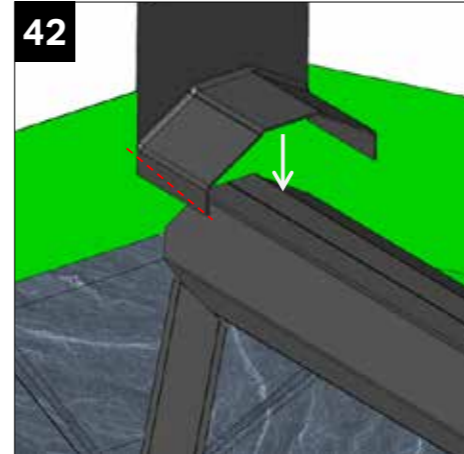

42 Fit and seal external ridge flashing cap using a low modulus silicone. Trim where necessary to sit properly on tiles.

TILE STOP CONDITIONS WHEN GLAZED

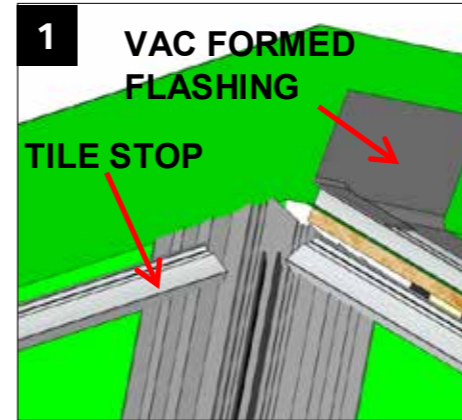

1 **GLAZING ON DUO-PITCH AND LEAN-TO**

If glazing is present on both the lean-to and the duo-pitch portions of the roof - tile stops will overlap the valley trough on both sides as shown. Position the tile stops using the Critical Dimension Sheet, and offset by 10mm from the centreline of the neighbouring glazing bar.

A vacuum formed flashing cover will also be supplied (see standard guide)

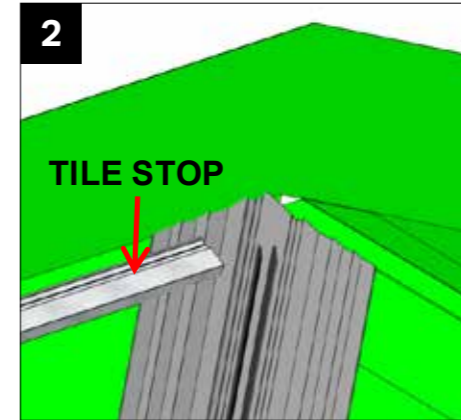

2 **GLAZING ON LEAN-TO ONLY**

If glazing is present on the lean-to portions of the roof only - a tile stop will overlap the valley trough on the lean-to side as shown. Position the tile stops using the Critical Dimension Sheet, and offset by 10mm from the centreline of the neighbouring glazing bar.

(No vacuum formed flashing cover is required.)

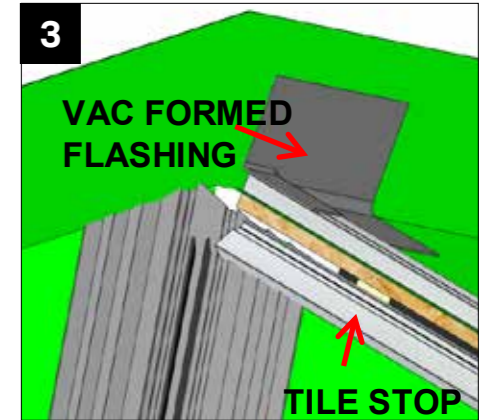

3 **GLAZING ON DUO-PITCH ONLY**

If glazing is present on the duo-pitch portion of the roof only - a tile stop will overlap the valley trough on the duo-pitch side as shown. Position the tile stops using the Critical Dimension Sheet, and offset by 10mm from the centreline of the neighbouring glazing bar.

A vacuum formed flashing cover will also be supplied (see standard guide)

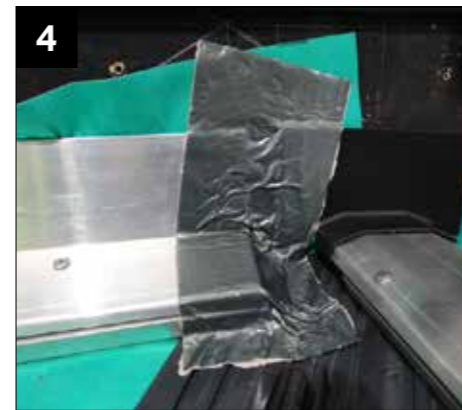

4 A 250mm square of Butyl tape is supplied to flash where glazed ridge caps (half ridge or duo pitch) finish at the top of the valley. Cut the square in half and install as shown, ensuring the adhesive side is firmly and consistently applied to all surfaces.

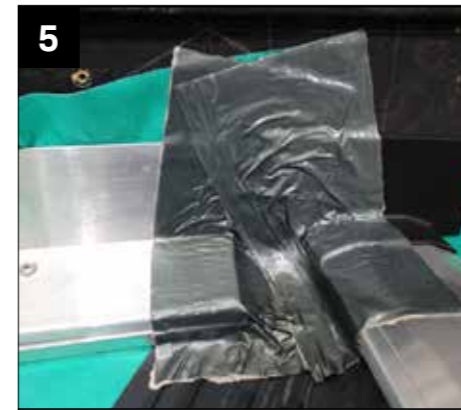

5 Image shows example where 2 butyl patches are applied where glazing is present on both lean-to and duo-pitch segments of the roof.



6 Image shows examples where 1 Butyl patch is applied - Glazing on duo-pitch segment (main image) and glazing on lean-to segment (inset image)

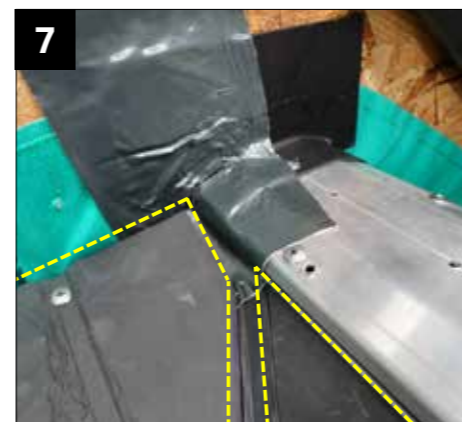

7 Tiles should butt up to side of valley trough as shown and may require trimming alongside ridge flashing cap.

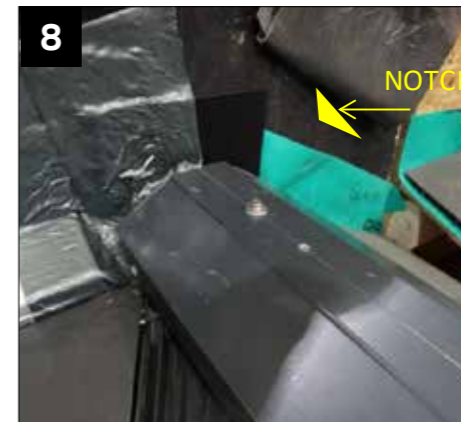

8 Fit aluminium ridge cap, which is pre-notched to avoid any interference approaching the valley.



9 Fit the supplied host wall flashing cap using a low modulus silicone.

L SHAPED RIDGE INFORMATION

Used in conjunction with main installation guide.

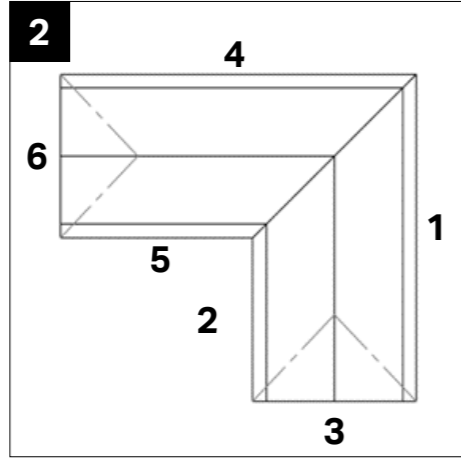
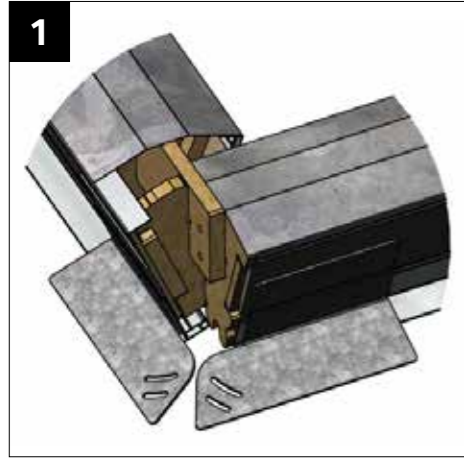

Assemble beams in sequence shown. Note: Example shows gable front; if Georgian or Victorian fronted, assemble front facet beams at stages 3 & 6.

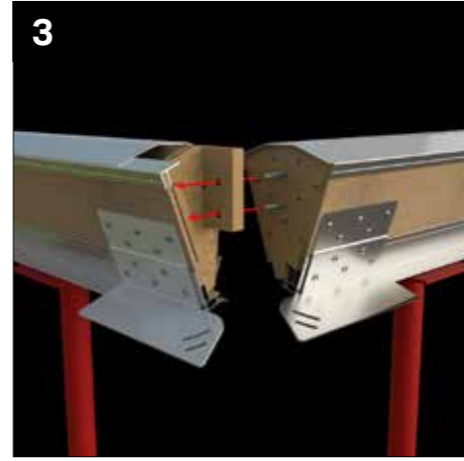

Support ridges using props with connecting features adjacent to each other.

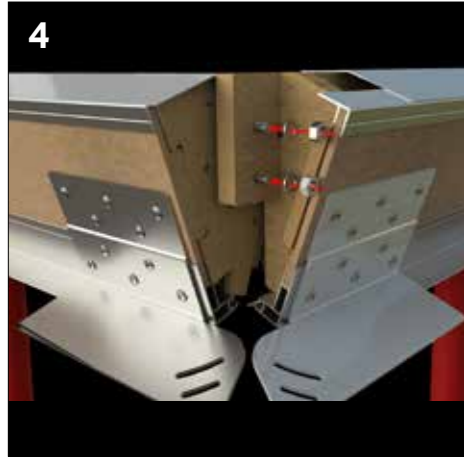

Locate bolts through corresponding corbel as shown. Fix using M8 nuts and washers (supplied).

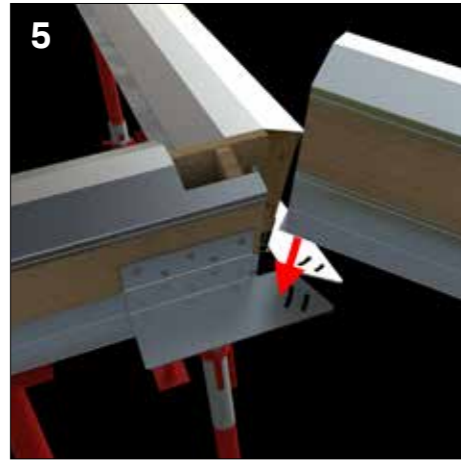

Install hip opposite valley, resting the ridge end on the hip support brackets. Fix at eaves as per standard installation.

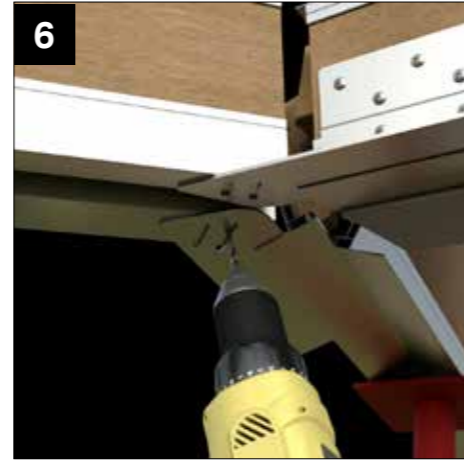

Fix to hip support bracket by drilling x 2 holes per wing and installing supplied bolts and flange nuts. NOTE: bolts should be installed with head internal to aid with plaster boarding.

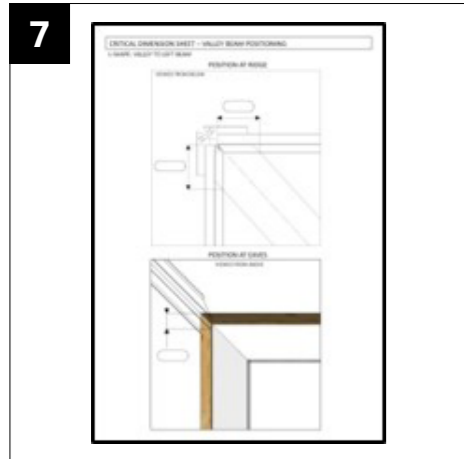

Install valley beam using supplied paperwork for correct positioning.



Valley position at ridge. Fix up through the ridge panel shelves using NRTS050 self drilling wafer head screws.



Valley position at eaves. Fix up through the eaves panel shelves using NRTS050 self drilling wafer head screws.

GENERAL VALLEY INSTALLATION

Used in conjunction with main installation guide.

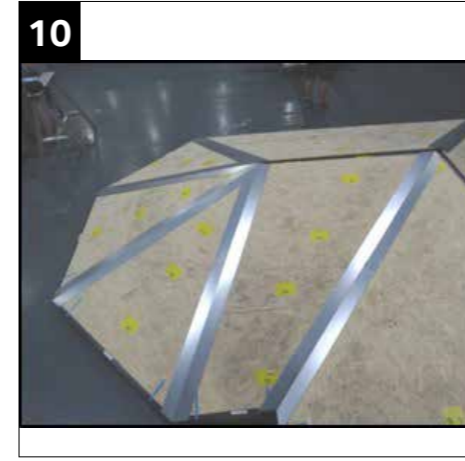

Now install the OSB and hip/valley steel plates as per main guide.

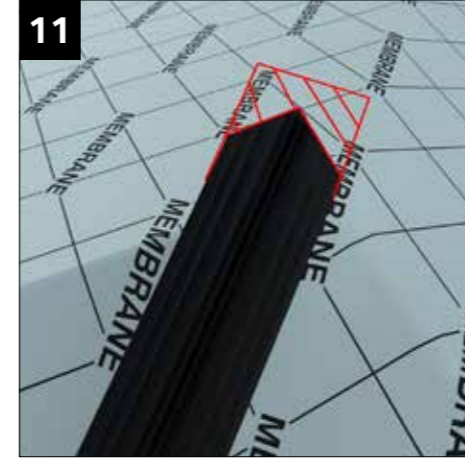

The Valley trough is supplied in 3 metre lengths. This should be installed over the breather membrane in the position shown before tiling.

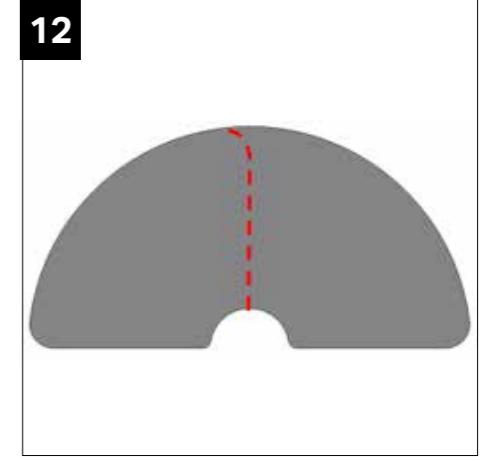

Modify supplied radius flashing patch as shown.

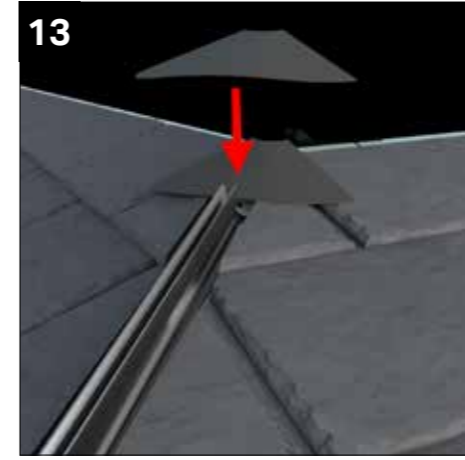

Position as shown using the L-shaped ridge connector as a guide for correct placement.

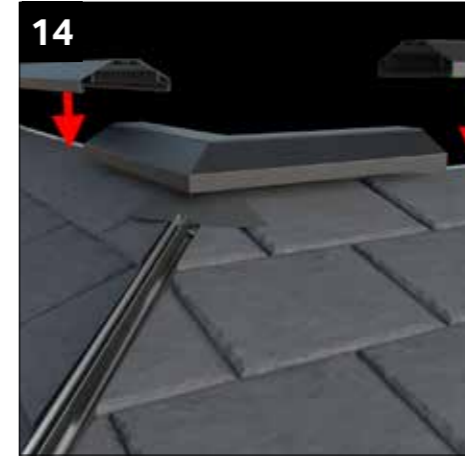

Fix ridge top capping and L-shaped ridge jointer using 5.5mm x 90mm (NRRSA 005BL) provided.

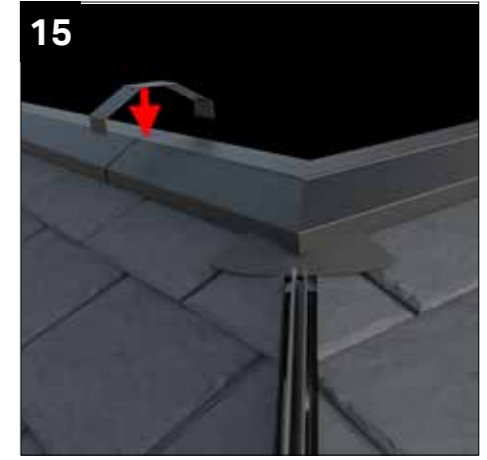

Place the supplied cover caps over the joint, adhering and sealing using appropriate silicone product (not supplied).

www.ultraframetrade.co.uk

Job No.: 3681 08/22 V2 NRVIG001

It is Ultraframe's policy to continually seek to improve its products, processes and services, and we reserve the right to change specifications without prior notice. Ultraframe is a trading name of Ultraframe (UK) Limited.

Ultraframe[®]

