

QUANTAL

QUANTAL

Distinctive Living

Product Overview

Familiar Quantal Roof Appearance



QUANTAL
Distinctive Living

Further Enhanced Aesthetic & Performance Improvements

Old Highly Visible Gasket Lines
On All Glazing Bars



New Upgraded, Low Profile
Glazing Bar Gaskets



Further Enhanced Aesthetic & Performance Improvements

Old Plastic, Basic Colour
External End Caps



New Contemporary, Colour
Matched Aluminium End Caps

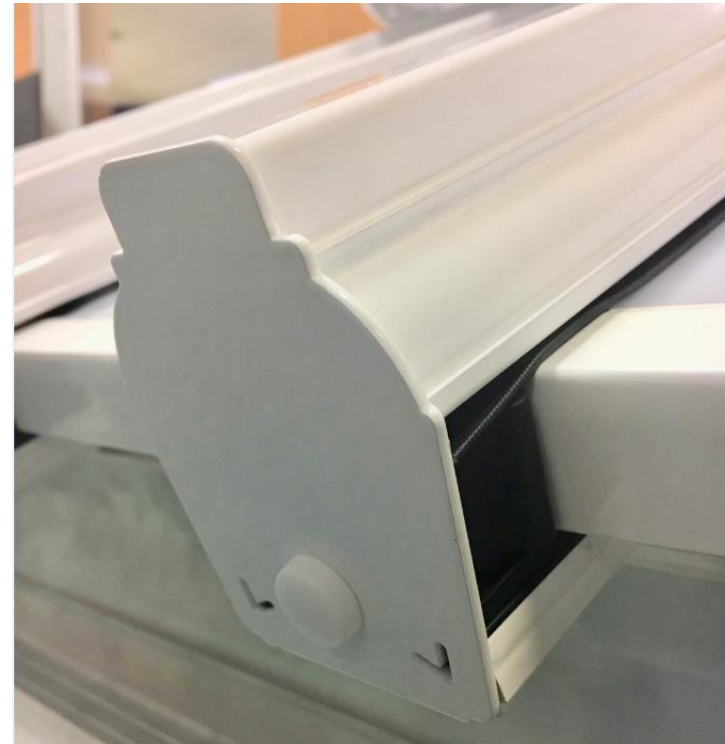

Easier/Faster Installation

Old Intricate Double Beaded
Glazing Bar Installation

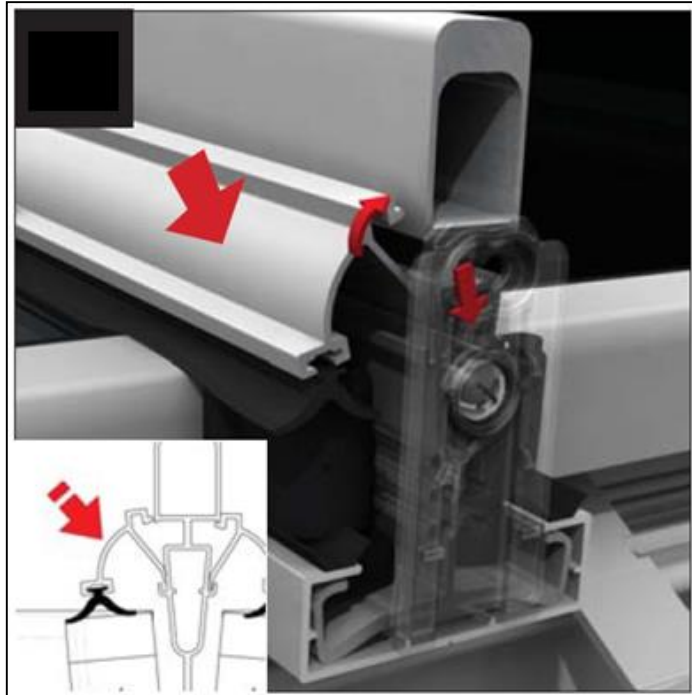

New Single Push Fit Top Capping
Installation



Technical Product Overview

Quantal Ridge - Thermally Broken

- **Ridge pitch range
5° - 40°**
- **Optional Cresting Adaptor Feature as
Standard**
- **Thermal break for ridge carriage**
- **Thermal shroud**
- **25/35mm glazing capabilities**
- **No secondary beading required.
integrated baffle arrangement**

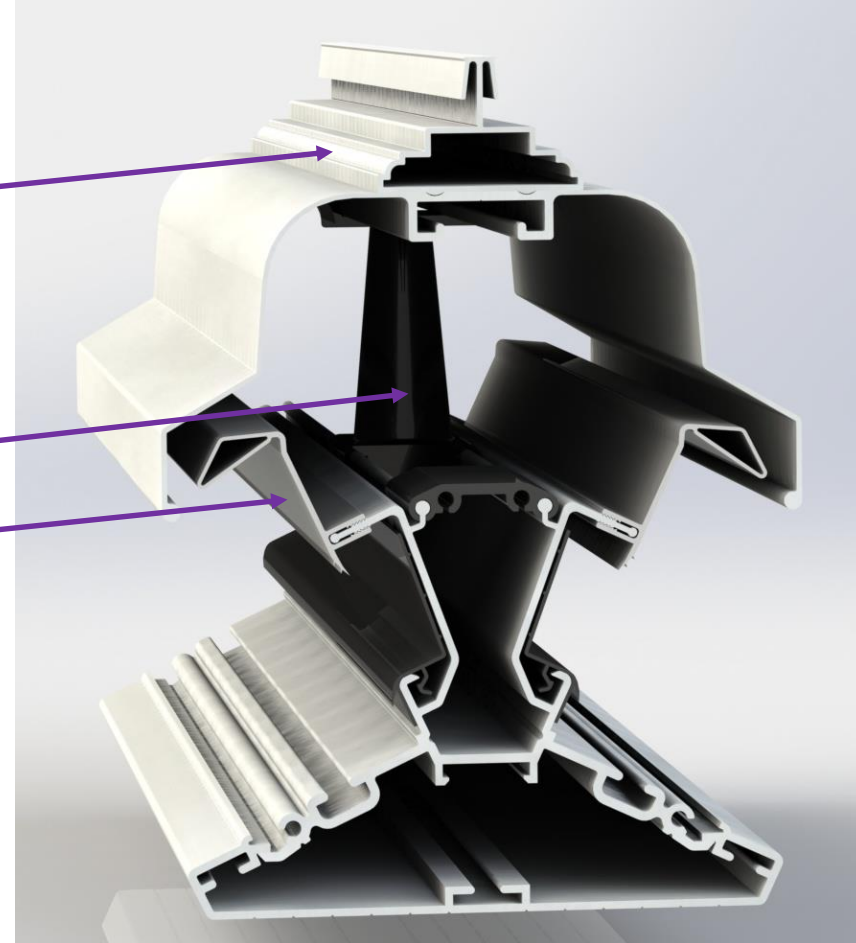

Quantal Ridge End



**A New Speedlock
radius end will be used.**

Quantal Ridge End

A new ridge end top cap is introduced to match the new ridge capping. The unique profiled gallery skirt and external appearance of ridge end is retained giving clean sharp lines.



New Quantal Transom Glazing Bar – Thermally Broken

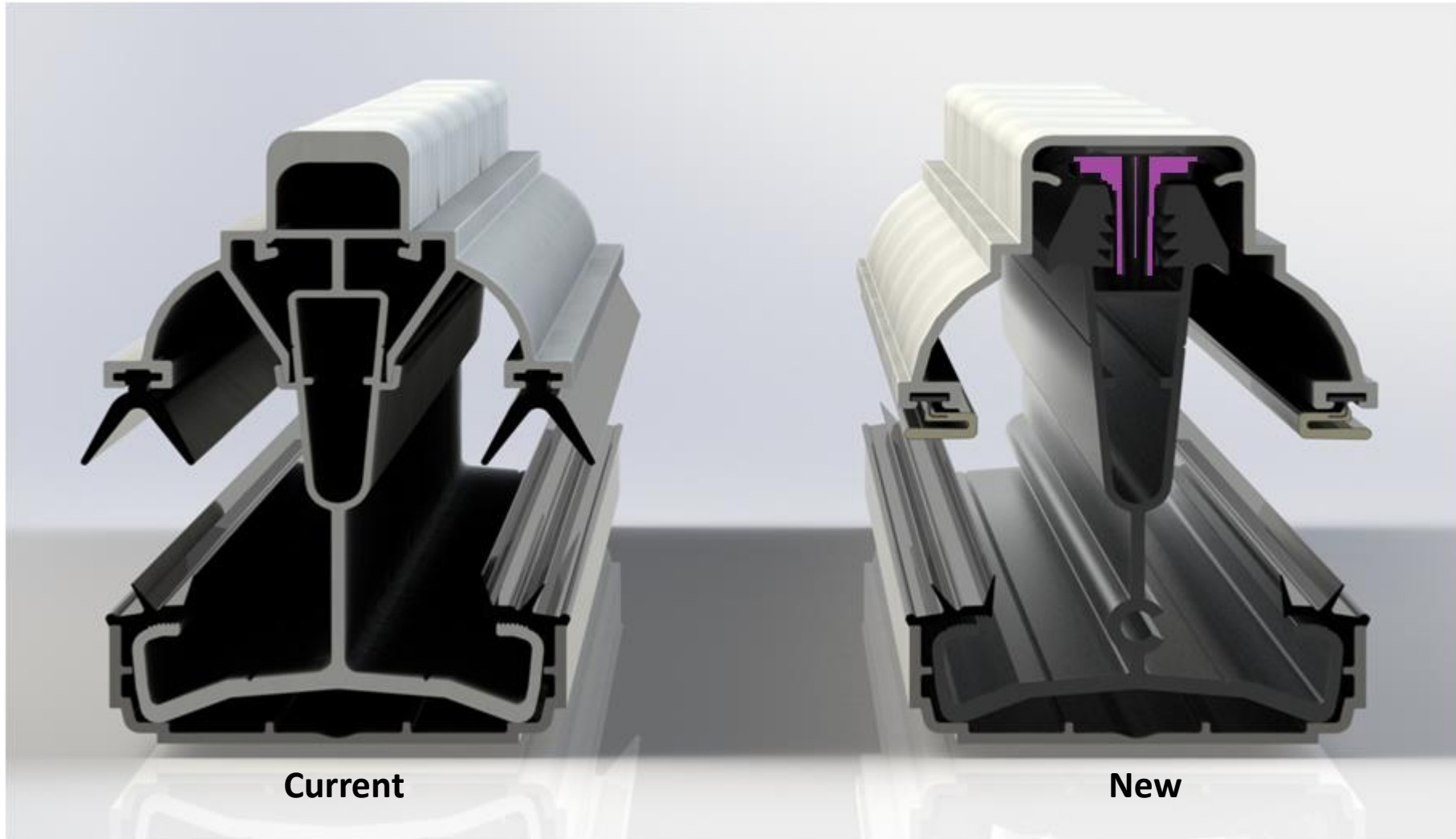

Current

New

New Quantal Square Top Cap Glazing Bar

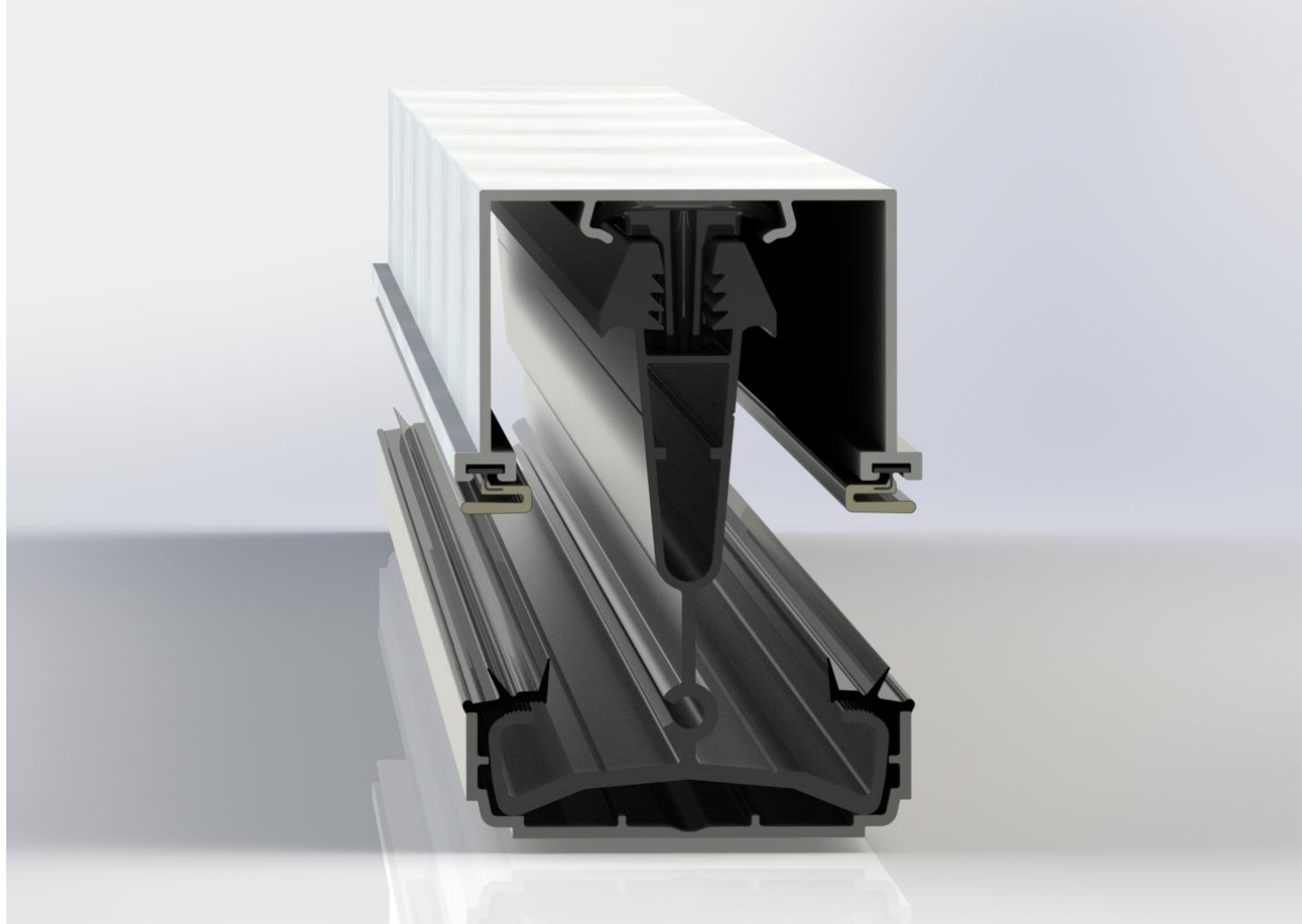

QUANTAL

Distinctive Living

New Aluminium Glazing Bar End Caps

New aluminium bar end caps
replace current plastic ones
to give a clean finish

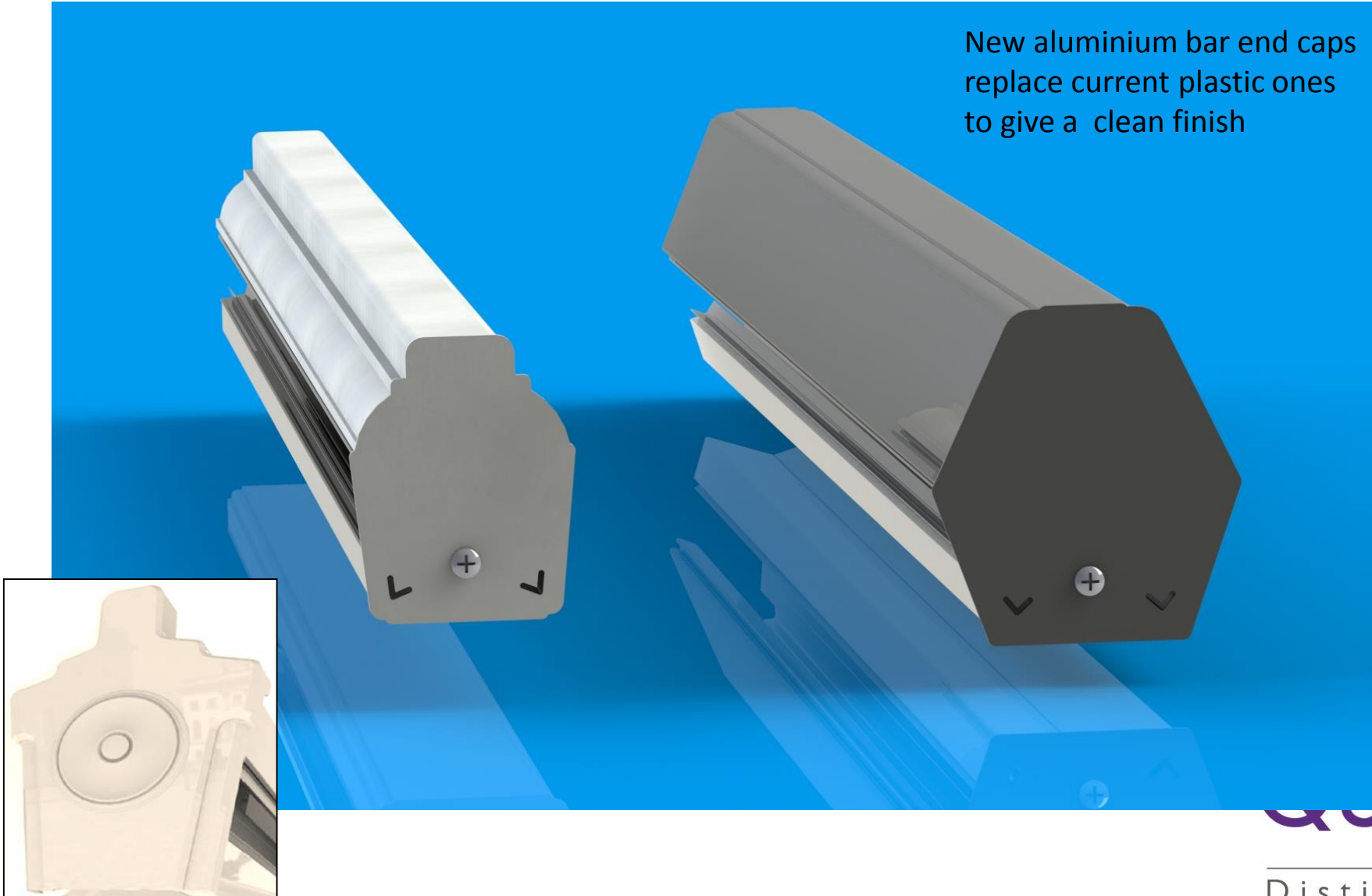

Quantal New Glazing Bar – Thermally Broken

New Glazing bar incorporates a thermal break and the cap is in one piece for speed of fitting and removing the need for beading.

- Thermal Break - improved thermal performance
- Cap one piece for speed of fitting
- Rubber gaskets replaced with Q-lon gaskets for long term performance
- Distinctive external look retained.

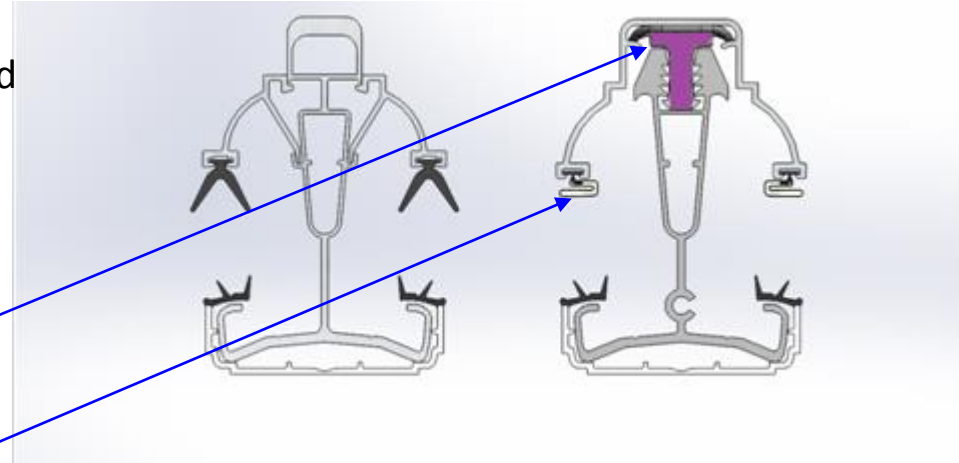

Thermal imaging shows a red warm surface on the underside of the new bar

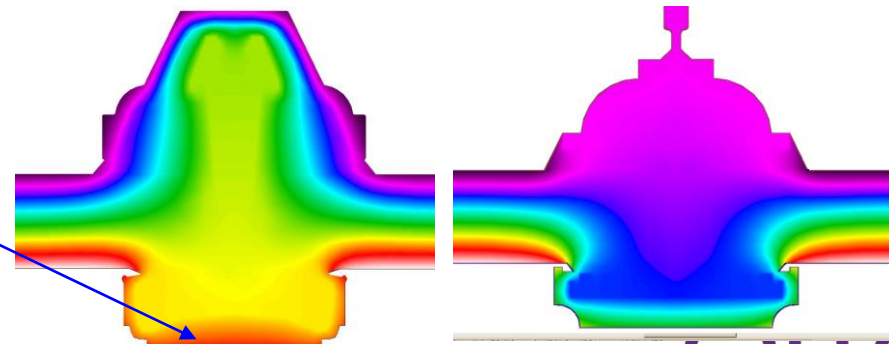

Quantal Valley

The Quantal valley bar is a tried and tested design capable of varied angles and glazing.

Glazing bars are fixed to the valley using a sliding bracket that fixes up the centre of the glazing bar.

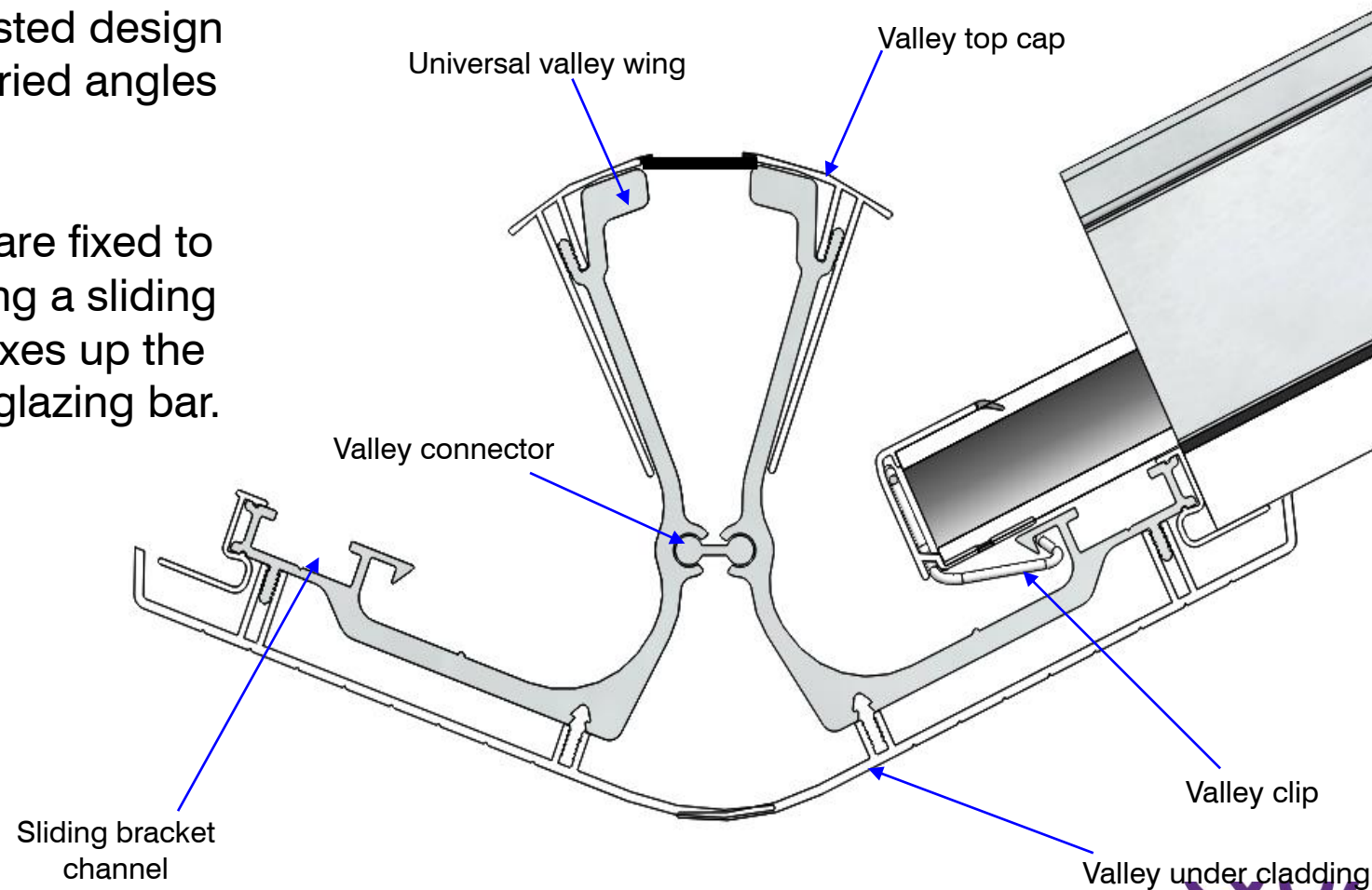

QUANTAL

Distinctive Living

New Eaves Beam (Standard Classic)

- Existing Quantal internal fascia replicated on the new eaves system
- Optional extras can be added with ease (external decorative Cornice and the internal insulated Pelmet)
- Snap-fit gutter bracket for gutter system.
- Eaves trickle vents available in glazing support
- Tried and tested system
- Pitch varies from 5°- 41° - no change

The new eaves can cater for over 90% of the current span requirements. The current eaves system and bolster will still be available as an optional upgrade in order to achieve greater spans

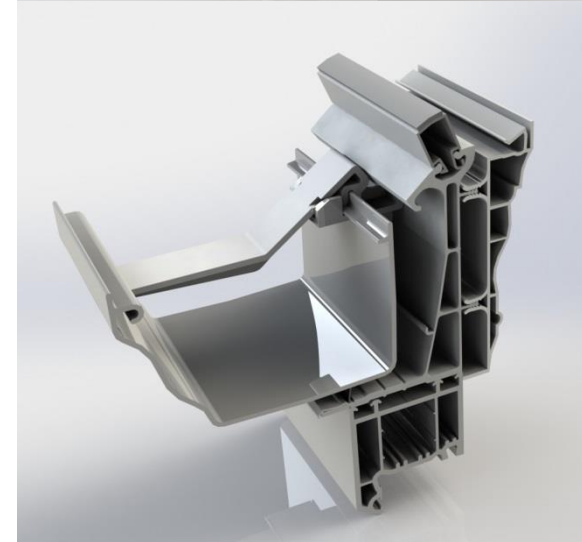
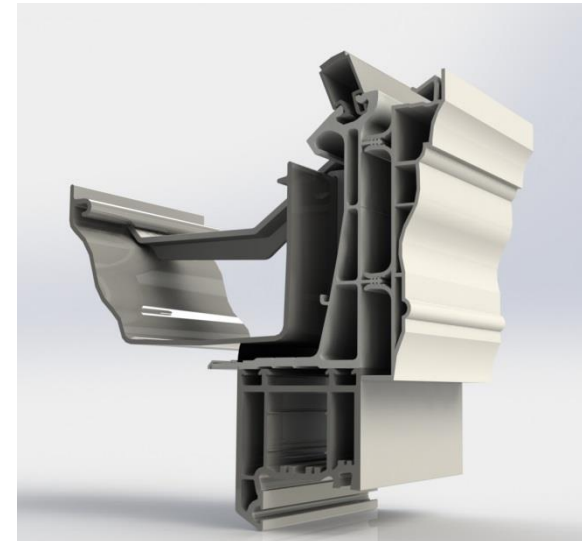

Quantal Internal Pelmet

The *Internal Pelmet* creates a perimeter ceiling that can be plastered and insulated up to a size of 1200mm.

This is achieved through an engineered frame work that is secured to the eaves beam and glazing bars to create a solid structure.

It combines all the benefits of a glazed extension in terms of light and then fuses this with the solidity and feel of a traditional extension.

The *Internal Pelmet* is variable in size between 300mm and 1200mm

Lights and speakers can be inserted into the pelmet to give a more 'room like' feel

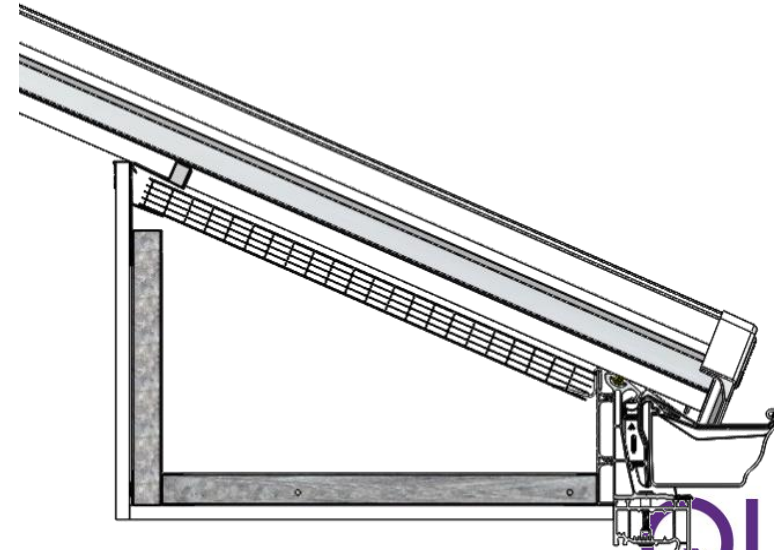

QUANTAL

Distinctive Living

Quantal Decorative Cornice

The Decorative Cornice is assembled from three sections to add a further degree of elegance to the Quantal roof.

The Cornice shrouds the gutter, in effect hiding the ends of the glazing bars to provide smooth clean lines at the eaves.

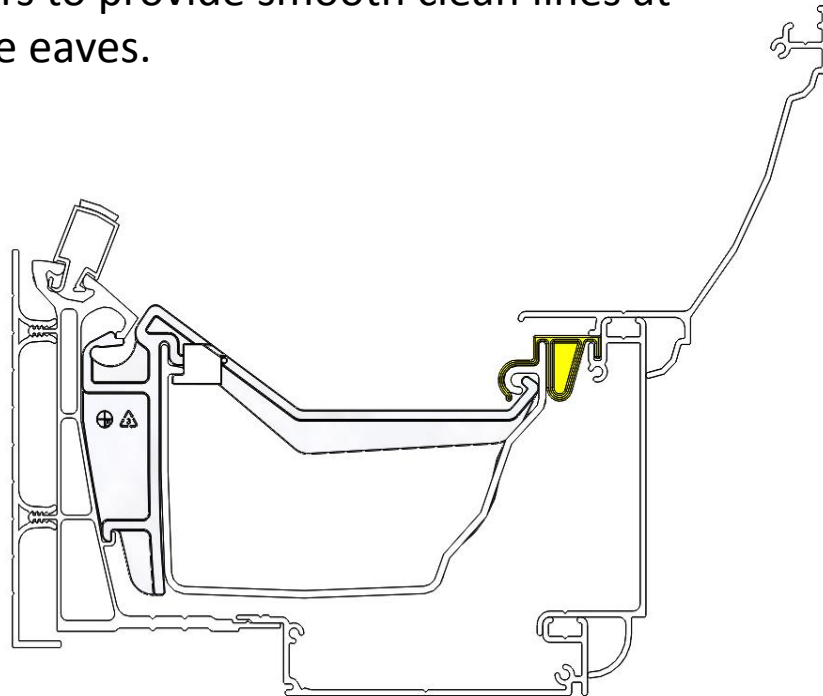

New Quantal Box Gutter Options

With the new eaves beam comes a new improved box gutter system. The system has the ability to be fitted easier and faster and contains less components.

- Works in conjunction with new eaves beam
- Parabolic head combined in box gutter extrusion
- 265mm and 165mm box gutter variations
- Strengthening straps don't require welding
- Hidden hanging bracket – replaces the need for gallows (165 box gutter only)
- Injection moulded gutter adaptors
- Specialised fabrication available

The current single width chambered box gutter will still be available as an upgrade where increased spanning capability is required between supports



165mm



265mm

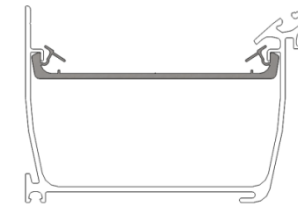

Strap

Hanging
Bracket

QUANTAL

Distinctive Living

Quantal Box Gutter Adaptors

- Contains full box gutter adapter suite (9 standard)
- Installed using tried and tested underwater curing sealant
- Bespoke manufacturing available for non standard angles and unique outlet situations

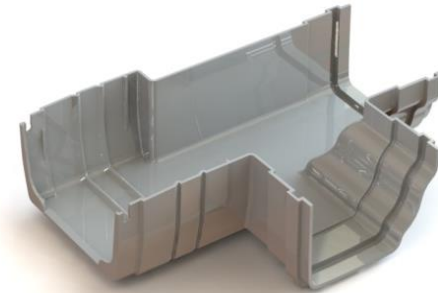

Injection Moulded box gutter adaptors

Other Features

Standard Colours

- White / Brown / Light Oak / Grey – Change from 80% Gloss to 30% Matt

Optional Premium Extras

- Aluminium Box Gutter Adapters
- Chambered Eaves Beam
- Chambered 165 Box Gutters